

ELEOS™ Limb Salvage System

Surgical Technique
Distal Femoral Replacement



The ELEOS Limb Salvage System offers options for patients with significant bone loss due to cancer, trauma, or previous surgical procedures. The locking taper design has a history of clinical use in a variety of orthopaedic applications. With an array of options in a multitude of sizes, the ELEOS system provides the surgeon the ability to meet a variety of patient needs.

 **ONKOS SURGICAL™**



ELEOS Limb Salvage System

DISTAL FEMORAL REPLACEMENT

TABLE OF CONTENTS:

PRODUCT DESCRIPTION

SURGICAL TECHNIQUE STEPS

FEMORAL PREPARATION

- FEMORAL AND TIBIAL RESECTION
- FEMORAL PLANING AND REAMING

TIBIAL PREPARATION

- TIBIAL REAMING
- TIBIAL RESECTION
- TIBIAL STEM EXTENSION (OPTIONAL)

TIBIAL BASEPLATE PREPARATION

- TIBIAL BASEPLATE REAMING
- TIBIAL BASEPLATE KEEL PUNCH

TRIALING

- TRIAL ASSEMBLY
- TRIAL REDUCTION

COMPONENT ASSEMBLY

- FEMORAL COMPONENT
- TIBIAL COMPONENT

CEMENT PREPARATION

COMPONENT INSERTION

- FEMORAL COMPONENT
- TIBIAL COMPONENT

PATELLA RECONSTRUCTION (OPTIONAL)

BLOCK AUGMENTS (OPTIONAL)

COMPONENT DISSASSEMBLY

EXPLANT INFORMATION

IMPLANT PART NUMBERS

INSTRUMENT PART NUMBERS

Proper surgical procedures and techniques are the responsibility of the medical professional. The following guidelines are furnished for informational purposes only. Each surgeon must evaluate the appropriateness of the procedures based on his or her personal medical training, experience and patient condition. Prior to the use of the system, the surgeon should refer to the product package insert for additional warnings, precautions, indications, contraindications and adverse effects. Instruction for use package inserts are available at www.onkossurgical/ELEOS/IFU.

PRODUCT DESCRIPTION

The ELEOS Distal Femoral System consists of eight components that create a hinged knee: the Segmental Stem, Optional Midsection, Distal Femoral Component, Tibial Hinge Component, Axial Pin, Tibial Baseplate, Tibial Polyethylene Spacer, and Optional Stem Extension.

NOTE | A Cemented Resurfacing Patella and Block Augments are available if needed.

The Distal Femoral Component (2500000(X)E) features a deepened patellar groove and a 5° valgus angle to assist in the restoration of patello-femoral kinematics, reduction of patellar subluxation and promotion of normal loading patterns. Internal/external rotation of the hinge can be controlled with a component that has a stop set for +/- 15° or a hinge component without a stop can be used.

Segmental Stems are available in a variety of diameters and lengths in both cemented and canal filling options. Cemented Stems provide flutes to enhance mechanical interlock of bone cement. Canal filling stems are splined and slotted (152mm only) and have plasma spray to enhance initial fixation.

Table 1.

Segmental Stems – Cemented				
Stem	Description	Length	Diameter	Collar
250000(X)E	Straight Cylindrical, Fluted, Titanium	152mm	11, 13mm	25mm
2500CC(X)E	Straight Cylindrical, Fluted Titanium	152mm	15, 17mm	32mm
SPSEB0(X)E	Bowed Cylindrical, Fluted, Titanium	152mm	11, 13, 15, 17mm	25mm
250040(X)E	Straight, Cylindrical, Fluted, Cobalt Chrome	120mm	9, 11, 13mm	25mm
Segmental Stems – Canal Filling				
SPSE00(X)E	Straight, Cylindrical Splined, Slotted, Titanium w/Plasma Spray 2/3	152mm	12, 14, 16, 18mm	25mm
2500CP(X)E	Straight, Cylindrical Splined, Slotted, Titanium w/Plasma Spray 2/3	152mm	12, 14, 16mm	32mm
2500BP(X)E	Bowed Cylindrical, Splined, Slotted, Titanium w/ Plasma Spray 2/3	152mm	12, 14, 16, 18, 20, 22mm	32mm
2500SP(X)E	Straight, Cylindrical, Splined, Full Plasma Spray, Titanium	120mm	12, 14, 16mm	25mm
2500SP(X)E	Straight, Cylindrical, Splined, Full Plasma Spray, Titanium	120mm	18, 20, 22mm	32mm

*Tapers down 2mm

Seven lengths of optional Midsection components (25001(X)0E) are interchangeable with all ELEOS Systems to allow for precise length determination intraoperatively. Lengths ranging from 40-140mm accommodate bone resections in 10mm increments.

The Tibial Baseplate (2500220(X)E) is available in five sizes for optimal tibial coverage. The Tibial Baseplate accepts cemented and canal filling Stem Extensions in a variety of lengths and diameters.

Table 2.

Stem Extensions – Cemented				
Stem	Description	Length	Diameter	Collar
KSC01530E	Straight, Cylindrical, Fluted, Titanium (bullet tip)	30mm	15mm	None
KSC0(XX)65E	Straight, Cylindrical, Fluted, Titanium	65mm	10, 12, 14, 16, 18mm	None
KSC(XX)100E	Straight, Cylindrical, Fluted, Titanium	100mm	10, 12, 14, 16, 18mm	None
Stem Extensions – Canal Filling				
KSP(XX)100E	Straight, Cylindrical, Splined, Slotted, Titanium	100mm	11, 12, 13, 14, 15, 16, 17, 18, 19, 21, 23mm	None
KSP(XX)140E	Straight, Cylindrical, Splined, Slotted, Titanium	140mm	11, 12, 13, 14, 15, 16, 17, 18, 19, 21mm	None

The Tibial Baseplate also accepts optional Block Augments that can be independently placed on the medial or lateral compartment to address specific patient bone deficiencies | **TABLE 3.**

Table 3.

BLOCK AUGMENTS		
PART #	DESCRIPTION	SIZE
KTAGB(XXX)E	ELEOS TIBIAL BLOCK AUGMENT	(1, 2, 3, 4, 5) X (5, 10, 15mm)

The Tibial Polyethylene Spacer (250012(XX)E) is available in 8, 10, 12, 16 and 20mm thicknesses.

Table 4.

FEMORAL BONE RESECTION

Part Number	Component	Resection
2500000(X)E	Distal Femur	65mm
N/A	Stem Collar	<u>5mm +1mm taper gap</u> =71mm
Midsections		
25001040E*	40mm	112mm
25001050E	50mm	122mm
25001060E	60mm	132mm
25001070E	70mm	142mm
25001090E	90mm	162mm
25001110E	110mm	182mm
25001140E	140mm	212mm

TIBIAL BONE RESECTION

Part Number	Component	Resection
N/A	Tibial Assembly ⁺	20mm ⁺

*Two 40mm Midsections are available to achieve desired resection lengths in 10mm increments

⁺The 20mm Tibial Resection is with an 8mm polyethylene spacer and the thickness of the Tibial Hinge Component (5mm metal and 2mm poly). The actual resection may be less depending on joint line positioning and ligament compliance.

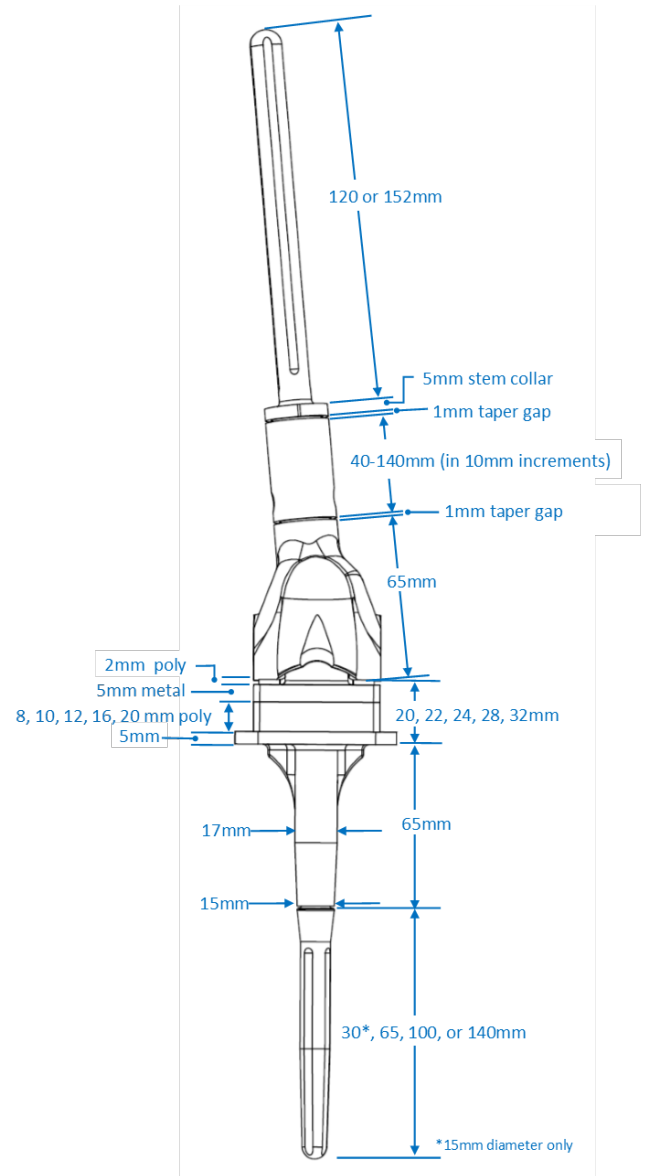

SURGICAL TECHNIQUE STEPS

FEMORAL PREPARATION

FEMORAL RESECTION

Preoperatively assess the amount of femoral and tibial bone to be resected. The amount of bone to be resected is determined by clinical evaluation.

NOTE | Following tumor resection, it is surgeon preference if the femoral resection or tibial resection is done first.

CAUTION | Preoperative templating is intended for estimation purposes only. Final component size and position should be determined intraoperatively. Accurate pre-operative planning requires good quality standardized radiographs of the appropriate anatomy.

CAUTION | A full femoral x-ray and/or 3 dimensional image or MRI must be reviewed prior to surgery to ensure adequate bone stock is available for resection and proper reaming.

A Distal Femoral Resection Template is available. When using the template, measure the level of resection from the distal end of the medial condyle.

Mark the level of resection determined during templating as seen in | **FIGURE 1.**

Resect the distal femur at the marked location, making a transverse cut | **FIGURE 2.**

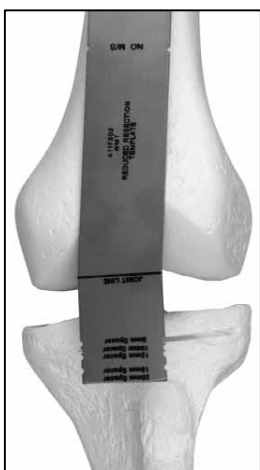

Figure 1.



Figure 2.

FEMORAL REAMING AND PLANING

Ream the (femoral) canal using Cylindrical Reamers if a cylindrical stem is to be implanted. Ream to a depth of 120mm or 152mm depending on the segmented stem chosen | **FIGURE 3**. If a bowed stem is chosen, a set of flexible reamers can be used from general surgical instrumentation. Select a stem diameter that corresponds to the appropriate cement mantle based on clinical evaluation | **TABLE 1**.

NOTE | The Segmental Stem diameters from Table 1 are equal to Reamer diameters. When determining the appropriate Cylindrical Reamer size for the desired cement mantle, the difference will represent the cement mantle. For instance, reaming to a 13mm diameter will provide a line-to-line fit with a 13mm stem. Reaming to a 14mm will provide a 0.5mm cement mantle per side, while reaming to 15mm will provide a 1mm cement mantle per side.

NOTE | The markings on the Reamer account for the additional material of the Resurfacing Femur (implant thickness and boss length). Therefore, a 65mm mark corresponds to an actual depth of 115mm, and a 100mm mark corresponds to an actual depth of 150mm length, and a 140mm mark to a depth of 190mm.

Utilize the appropriate size Resection Planer to plane the resection area at the resection level | **FIGURE 4**. Use the Resection Planer closest in diameter to the diameter of the intramedullary canal at the resection level.



Figure 3.



Figure 4.

TIBIAL PREPARATION

The tibial resection is performed using Intramedullary (IM) Referencing instrumentation. Consider that the Tibial Components (Tibial Baseplate, Tibial Polyethylene Spacer, and Tibial Hinge Component) will add 20mm of length when using an 8mm spacer; confirm that enough tibial bone is removed.

NOTE | The ELEOS Tibial implants are designed for a perpendicular tibial base orientation to the IM canal. Hence, IM instrumentation helps ensure a neutral resection.

TIBIAL REAMING

A Starter Drill Bit 3/8 in. is used to initiate an opening in the proximal tibia just posterior to the anterior cruciate ligament tibial attachment.

NOTE | Drill to approximately 1-1.5 inches in depth and toggle the drill to increase the opening diameter to allow the 11 in. Reamer/IM Rod to locate the central axis.

Attach the Quick Disconnect T-handle to the 11 in. Reamer/ IM Rod and ream to establish the anatomical axis of the proximal tibia | **FIGURE 5** and to allow for the assembly of the IM Tibial Alignment Guide.

NOTE | If Stem Extensions are to be used, continue reaming with consecutive larger reamer diameters until the desired diameter is achieved after the tibial resection has been made. See "Tibial Stem Extensions (Optional)."

CAUTION | Hand reaming is recommended when a patient has poor bone quality.

TIBIAL RESECTION

Preassemble the IM Tibial Alignment guide and IM Tibial Resection guide on the back table. Remove the Quick Disconnect T-Handle from the 11 in. Reamer/IM Rod.

Slide the IM Tibial Alignment and Resection Guide Assembly onto the 11 in. Reamer/ IM Rod until the bottom surface of the guide rests against the tibial surface | **FIGURE 6**.

Turn the locking screw to lock the guide to the 11 in. Reamer/IM Rod **A IN | FIGURE 6**.

The Depth Stylus and/or Dual Reference Gauge (also known as crab claw/angel wing) can be used to set the proximal/distal



Figure 5.

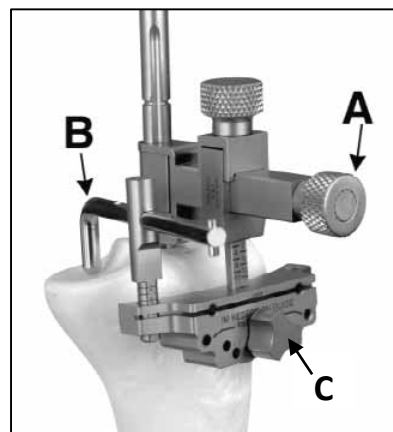

Figure 6.

position of the IM Tibial Resection guide to the desired level of tibial resection **B IN | FIGURE 6.**

NOTE | The IM Tibial Resection Guide can be moved an additional 3mm down if the initial pin is placed in the “0” hole to get the desired resection level.

The Depth Stylus can be set to measure a depth of resection of 2mm or 10mm.

After desired resection level is achieved, tighten the knob on the IM Tibial Resection Guide. **C IN | FIGURE 6.**

Pin the IM Tibial Resection Guide to the proximal tibia.

After the desired alignment is achieved and pins are in place, loosen the locking screw **A IN | FIGURE 6** and knob on the IM Tibial Resection Guide **C | IN FIGURE 6.** Remove the top of the IM Tibial Alignment Guide leaving the IM Tibial Resection Guide pinned into the tibia.

Make the tibial resection and remove the IM Tibial Resection Guide.

TIBIAL STEM EXTENSIONS (Optional)

Stem Extensions are available in either canal filling or cemented options | **See Table 2.** If a Stem Extension is to be used, continue reaming with consecutive larger reamer diameters until the desired diameter is achieved.

Cylindrical Reamers are available in 10mm-23mm diameters in 0.5mm increments and are marked for 65mm, 100mm, and 140mm stem lengths **A IN | FIGURE 7.**

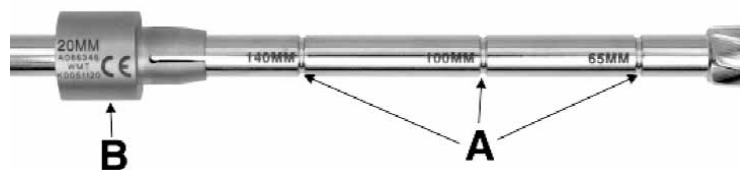

Figure 7.

CAUTION | Hand reaming may be appropriate to avoid thinning the tibial cortex which could result in a fracture.

NOTE | The markings on the Reamer account for the additional material of the resurfacing femur (implant thickness and boss length). Therefore, a 65mm mark corresponds to an actual depth of 115mm, a 100mm mark corresponds to an actual depth of 150mm length, and a 140mm mark to a depth of 190mm.

NOTE | Due to the length of the Tibial Baseplate, ream approximately 20mm past the 65mm, 100mm, and 140mm mark on the Reamers to accommodate the appropriate resurfacing stem. These marks are referenced on the tibial plateau after the tibial resection.

NOTE | The Stem Extension diameters from Table 2 are equal to Reamer diameters. When determining the appropriate Cylindrical Reamer size for the desired cement mantle, the difference will represent the cement mantle. For instance, reaming to a 13mm diameter will provide a line-to-line fit with a 13mm stem. Reaming to a 14mm will provide a 0.5mm cement mantle per side, while reaming to 15mm will provide a 1mm cement mantle per side.

With desired reaming complete, ensure the Reamer provides a stable construct for additional tibial preparation.

NOTE | If additional stability is required due to a large opening at the proximal tibia, Stabilizing Collets **B IN | FIGURE 7** are available in 16mm, 18mm, 20mm, 22mm, and 24mm diameters.

TIBIAL BASEPLATE PREPARATION

Select the Trial Tibial Baseplate Template that provides the optimal proximal tibial bone coverage | **FIGURE 8**.

NOTE | If Augments are used, see “Block Augments (Optional)” on **Page 19** and attach the appropriate size and thickness Trial Augment to the Trial Tibial Baseplate Template.

Place the Trial Tibial Baseplate Template on the proximal tibia. If the size is appropriate, attach the Trial Tibial Base Handle/Drill Guide and External Check Rod and place the Trial Tibial Baseplate Template on the proximal tibia and pin it to the tibia using Tibial Baseplate Fixation Pins | **FIGURE 9**.

NOTE | Align the distal end of the External Check Rod with the second toe.

Remove the Tibial Baseplate Handle and External Check Rod.

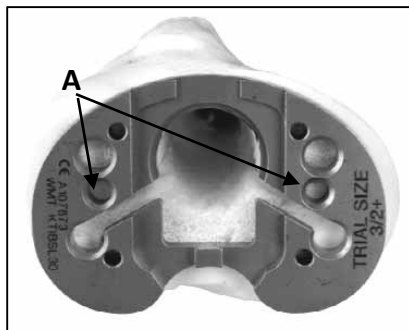

Figure 8.



Figure 9.

Loosely attach the Keel Punch Guide Handle to the Keel Punch Guide. Align the pegs on the bottom of the Keel Punch Guide to the center holes in the Trial Tibial Baseplate Template **A IN | FIGURE 8**.

Secure the Keel Punch Guide to the Trial Tibial Baseplate by turning the knurled handle, ensuring that the Keel Punch Guide Handle is in the correct orientation shown in **A IN | FIGURE 10.**

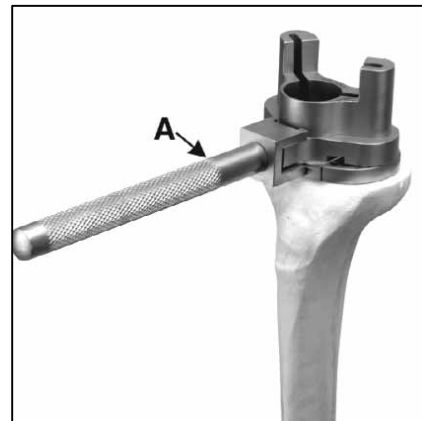

Figure 10.

TIBIAL BASEPLATE REAMING

Align the Press Fit Reamer Guide or Cemented Reamer Guide through the Keel Punch Guide **A IN | FIGURE 11.** If a thin cement mantle is preferred, utilize the Press Fit Reamer Guide and Press Fit Reamer; if a thicker cement mantle is preferred, use the Cemented Reamer Guide and Cemented Reamer.

Using the appropriate reamer, ream until no teeth are visible above the Reamer Guide | **FIGURE 11.**

NOTE | Make certain that the Tibial Baseplate Template stays flush to the resection surface during the reaming and punching steps.

Remove the Reamer Guide from Keel Punch Guide.

TIBIAL BASEPLATE KEEL PUNCH

Using the Keel Punch Impactor and the Press Fit or Cemented Keel Punch, slide the punch through the guide until the punch is fully seated | **FIGURES 12 AND 13.** If Stem Extension reaming was performed, attach appropriate size Trial Stem Extension to the chosen Keel Punch.

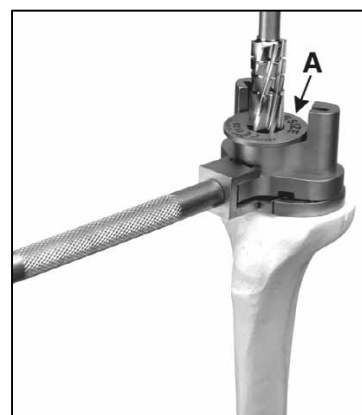

Figure 11.

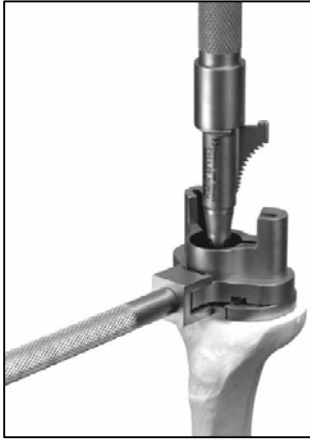

Figure 12.

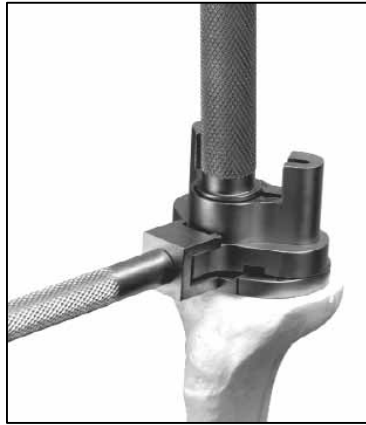

Figure 13.

Disassemble and remove all tibial preparation instruments. Use the Pin Puller to remove fixation pins.

TRIALING

TRIAL ASSEMBLY

Assemble appropriate femoral trials, including the Trial Distal Femur, Trial Segmental Stem, and any Trial Midsections necessary to reproduce the appropriate leg length.

NOTE | To reproduce the appropriate leg length within 10mm increments, two 40mm Trial Midsections are available in the instrumentation tray.

To assemble the Trial Midsections to the Trial Stems, lift the sliding portion of the quick connect mechanism of the trial component, engage the post, aligning the tab with the slot, then release | **FIGURE 14.**



Figure 14.

Place the femoral trial construct into the femoral canal.

NOTE | When assembling a Bowed Trial Stem, ensure that the bow is in alignment with the curve of the bone.

Assemble the Trial Tibial Baseplate, Trial Stem Extension (optional), Trial Tibial Poly Spacer and Trial Tibial Hinge Component according to previously determined sizes chosen | **FIGURE 15-16.**

Insert the trial tibial component assembly into the tibia | **FIGURE 16.**



Figure 15.



Figure 16.

Reduce the trial femoral construct onto the trial hinge component. Next, insert the Trial Axial Pin to attach the Trial Distal Femur to the Trial Tibial Hinge Component to secure the construct for trial reduction | **FIGURE 17.**

NOTE | The Trial Axial Pin can be inserted from the medial or lateral side | **FIGURE 18.**



Figure 17.



Figure 18.

TRIAL REDUCTION

Perform a trial reduction. Determine rotational alignment using the groove on the femoral Trial Segmental Stem and the linea aspera for reference | **FIGURE 19**. Mark the rotational position at the resection level. This will mark the position for the final implant. If the overall leg length requires adjustment, minor changes can be accomplished by selecting alternate poly spacers. More significant adjustments may require altering the choice of midsection lengths and/or changing the resection level.

COMPONENT ASSEMBLY

FEMORAL COMPONENT

If a Midsection is to be used, assemble the Distal Femur and Midsection. On the back table, place the Distal Femur and Midsection in the Femoral Assembly Platform using the Trial Axial Pin, and assemble with five hard mallet blows using the Midsection Assembly Impactor | **FIGURE 20**.

Place the Segmental Stem into the Midsection Component, or into the Distal Femur if no Midsection was used, and assemble with five hard mallet blows using the Stem Assembly Impactor | **FIGURE 21**.

NOTE | Recommend using 2lb mallet from general surgical OR instruments.



Figure 19.



Figure 20.



Figure 21.

TIBIAL COMPONENT

If a Stem Extension is to be used, place the Tibial Baseplate on the Tibial Baseplate Assembly Platform. Assemble the Stem Extension onto the Tibial Baseplate using five hard mallet blows directly on the tip of the stem with Stem Assembly Impactor | **FIGURE 22.**



Figure 22.

NOTE | Make sure to remove the protective cap on the tip of the Stem Extension before assembly.

If augments are to be used see "Block Augments (Optional)."

PREPARATION OF CEMENT

Cement mixing begins and the femoral and tibial canals are cleaned using pulsating lavage and then dried with a femoral sponge or tampon. If desired, a cement restrictor (plug) can be placed in the canal. Cement is injected in a pressurized retrograde fashion.

COMPONENT INSERTION

FEMORAL COMPONENT

Place the assembled implant in the femoral canal, aligning the mark on the stem with the mark on the femur previously made | **FIGURE 23**. Guide and impact the stem into the canal with the Femoral Impactor until the stem is fully seated at the resected plane | **FIGURE 24**. Remove excess cement. Proper position of the implant should be maintained until the cement cures.



Figure 23.



Figure 24.

TIBIAL COMPONENT

A marking on the anterior portion of the Tibial Baseplate boss provides a reference to align the slot of the Stem Extension when a canal filling stem is indicated | **FIGURE 25**.

NOTE | The slot on the Stem Extension **B** IN | **FIGURE 25** should align with the marking on the Tibial Baseplate boss **A** IN | **FIGURE 25**.

Place the Tibial Baseplate and Tibial Poly Spacer into the canal using the Tibial Impactor | **FIGURE 26**. Care should be taken to anchor the final components in the appropriate position until the cement has set fully.

TIBIAL HINGE ASSEMBLY

Insert the Tibial Hinge Component into the Tibial Poly Spacer | **FIGURE 27**.

Align the Distal Femur with the Tibial Hinge Component | **FIGURE 28**.

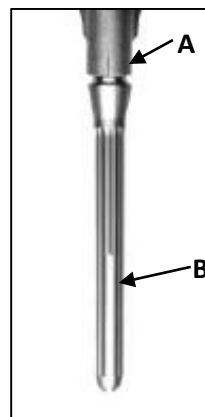

Figure 25.



Figure 26.



Figure 27.



Figure 28.

Insert the Distal Femur Axial Pin using the Axial Pin Inserter/Extractor Instrument | **FIGURES 29-32.**

The Distal Femur Axial Pin can be inserted either on the medial or lateral side. The Axial Pin key must fall into the corresponding keyway in the femoral component. Make sure the Axial Pin is flush with the side of the Distal Femur | **FIGURE 32.**



Figure 29.



Figure 30.



Figure 31.



Figure 32.

NOTE | To help align the components, the Trial Axial Pin can be inserted part way into the opposite side of the final Axial Pin insertion. Then insert the Axial Pin into the other end and advance the pin forward, ejecting the Trial Axial Pin. Engage the Axial Pin until it is flush on both sides of the Distal Femur.

PATELLAR RECONSTRUCTION (Optional)

Patella resurfacing is determined based on medical judgment of the clinical situation. If severe degeneration or arthritis is present on the articular surface of the patella, resurfacing may be indicated. If the patella is otherwise normal, such as in a tumor case, and has not been removed for malignant considerations, it may be acceptable to resurface the patella or to leave it in its natural state.

RESURFACING PATELLA

The Resurfacing Patella Resection Guide can be used with or without Resection Depth Gauges or Minimum Thickness Gauges | **FIGURE 33.** When used without gauges, the Resection Guide is positioned at the desired level of resection.



Figure 33.

Securely clamp the jaws into the patella and resect the patellar bone. For a calibrated resection, the appropriate Resection Depth Gauge corresponding to the implant thickness should be attached to the top of the resection guide with the lock screw. Position the resection guide jaws parallel to the articular margin and securely clamp the guide to the bone, assuring the gauge is contacting the apex of the articular surface. The gauge can be removed to increase visibility.

Resurfacing Patella Minimum Thickness Gauges are available for preservation of 10mm or 15mm bone stock. Use of the Minimum Thickness Gauge is based on intraoperative assessment of bone quality and thickness.

Resurfacing Patella, All-Poly, Tri-Peg			
Part Number	Description	Diameter	Thickness
KPONT29E	ELEOS RESURFACING PATELLA	29mm	8mm
KPONT32E	ELEOS RESURFACING PATELLA	32mm	8mm
KPONT35E	ELEOS RESURFACING PATELLA	35mm	8mm
KPONT38E	ELEOS RESURFACING PATELLA	38mm	10mm
KPONT41E	ELEOS RESURFACING PATELLA	41mm	11mm

The Resurfacing Peg Drill Guide is used to size the patella and prepare holes in the bone for the implant pegs. Attach the Resurfacing Peg Drill Guide to the Patella Clamp. The Drill Guide has grooves on the surface indicating the patella diameter options. The Resurfacing Patella Peg Drill is used to prepare the peg holes | **FIGURE 34**.

NOTE | The Resurfacing Patella have the same peg patterns between sizes and can be easily changed during trial reduction.

NOTE | A Patella/Femoral Head Sizing Caliper is available for assessment of thickness.

Remove the Resurfacing Patella Drill Guide from the Patella Clamp and insert the Patella Clamp Seater in its place.

Once the patella surface is prepared, mix cement, wash and dry the bone, pressurize the cement, and insert the patella pegs into the prepared holes. Use the Patella Clamp with the Patella Clamp Seater attached to fully seat the Patella. Remove residual cement, and keep the Patella Clamp in place until cement is cured.

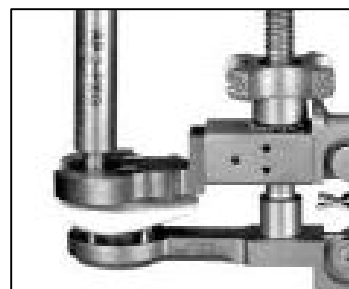

Figure 34.

BLOCK AUGMENTS (Optional)

During the tibial resection step of the surgical technique, if Block Augments are necessary, begin by making a proximal "clean-up" resection along the most prominent condyle through the 0mm resection slot marked "STD" in the Revision Block Augment Resection Guide **A IN | FIGURE 35.**

NOTE | The Revision Block Augment Resection Guide is available in a right and left hand version.

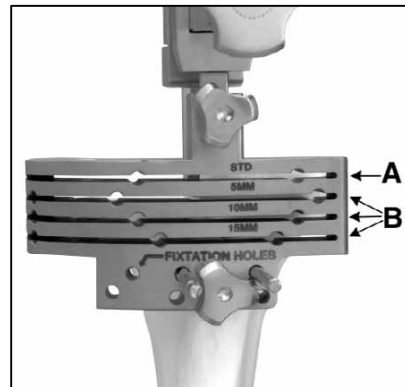

Figure 35.

If block augmentation is needed, the Revision Block Augment Resection Guide provides resection slots for the 5mm, 10mm, and 15mm Augments. **B IN | FIGURE 35.**

These Augments can be placed independently on the medial or lateral side of the tibia.

During tibial baseplate preparation, if an Augment is to be used, attach the appropriate size Block Augment to the Trial Tibial Baseplate Template and proceed with tibial preparation, as specified above | **FIGURE 36.**

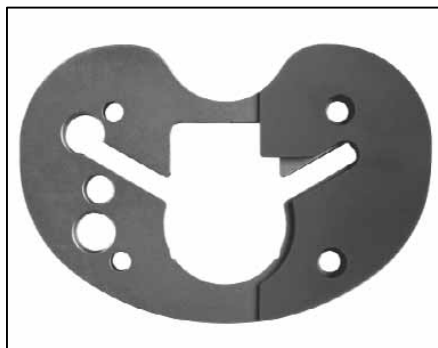

Figure 36.

During component assembly, attach the Augment by aligning the three centering pegs on the Tibial Augment with the three recessed areas of the Tibial Baseplate.

ELEOS Limb Salvage System

Using the packaged screws, assemble the augments through the Tibial Baseplate. Plastic starter handles are provided with each augment screw and should be removed once the screw is tightened | **FIGURE 37**. A final tightening of the Augment should be completed with a standard 3.5mm hex head screwdriver.



Figure 37.

COMPONENT DISASSEMBLY

To disengage the ELEOS segmental tapers, insert the Taper Disassembly Tool into the hole on the side of the implant. Strike the end of the tool with a mallet until the components separate | **FIGURES 38 AND 39.**

Support the implant during disassembly. Alternatively, or in concert with disassembly tools, insert the Taper Disassembly Fork around the outside of the implant, below the seam between the two components to be disassembled. Strike the end of the fork to disengage the tapers | **FIGURES 40 AND 41.** Again, support the implant during disassembly.



Figure 38.



Figure 39.



Figure 40.



Figure 41.

EXPLANTATION INFORMATION

In a revision case, when Segmental Stem explantation is required, use the Stem Extractor Attachment and attach to the Slap Hammer Extractor Handle to remove the stem. To disengage Stem Extensions, use the Stem Implant Extractor-Adaptor. Assemble it to the Slap Hammer Pin Extractor. Next, thread the full assembly to the Stem Extension that needs to be removed. A Trefine from general surgical instrumentation can also be used to remove the stem by placing the Trefine over the stem to ream the interface between the stem and the bone.

IMPLANTS

SEGMENTAL STEMS (CEMENTED)

PART NUMBER	DESCRIPTION	SIZE
25004009E	ELEOS SEGMENTAL STEM	9MM X 120MM
25004011E	ELEOS SEGMENTAL STEM	11MM X 120MM
25004013E	ELEOS SEGMENTAL STEM	13MM X 120MM
25000011E	ELEOS SEGMENTAL STEM	11MM X 152MM
25000013E	ELEOS SEGMENTAL STEM	13MM X 152MM
2500CC15E	ELEOS SEGMENTAL STEM	15MM X 152MM
2500CC17E	ELEOS SEGMENTAL STEM	17MM X 152MM
SPSEB011E	ELEOS SEGMENTAL STEM	11MM X 152MM
SPSEB013E	ELEOS SEGMENTAL STEM	13MM X 152MM
SPSEB015E	ELEOS SEGMENTAL STEM	15MM X 152MM
SPSEB017E	ELEOS SEGMENTAL STEM	17MM X 152MM

SEGMENTAL STEMS (CANAL FILLING)

PART NUMBER	DESCRIPTION	SIZE
2500SP12E	ELEOS SEGMENTAL STEM	12MM X 120MM
2500SP14E	ELEOS SEGMENTAL STEM	14MM X 120MM
2500SP16E	ELEOS SEGMENTAL STEM	16MM X 120MM
2500SP18E	ELEOS SEGMENTAL STEM	18MM X 120MM
2500SP20E	ELEOS SEGMENTAL STEM	20MM X 120MM
2500SP22E	ELEOS SEGMENTAL STEM	22MM X 120MM
2500BP12E	ELEOS SEGMENTAL STEM	12MM X 152MM
2500BP14E	ELEOS SEGMENTAL STEM	14MM X 152MM
2500BP16E	ELEOS SEGMENTAL STEM	16MM X 152MM
2500BP18E	ELEOS SEGMENTAL STEM	18MM X 152MM
2500BP20E	ELEOS SEGMENTAL STEM	20MM X 152MM
2500BP22E	ELEOS SEGMENTAL STEM	22MM X 152MM
2500CP12E	ELEOS SEGMENTAL STEM	12MM X 152MM
2500CP14E	ELEOS SEGMENTAL STEM	14MM X 152MM
2500CP16E	ELEOS SEGMENTAL STEM	16MM X 152MM
SPSE0002E	ELEOS SEGMENTAL STEM	12MM X 152MM
SPSE0003E	ELEOS SEGMENTAL STEM	14MM X 152MM
SPSE0004E	ELEOS SEGMENTAL STEM	16MM X 152MM
SPSE0005E	ELEOS SEGMENTAL STEM	18MM X 152MM

MALE-FEMALE MIDSECTIONS

PART NUMBER	DESCRIPTION	SIZE
25001040E	ELEOS MALE-FEMALE MIDSECTION	40MM
25001050E	ELEOS MALE-FEMALE MIDSECTION	50MM
25001060E	ELEOS MALE-FEMALE MIDSECTION	60MM
25001070E	ELEOS MALE-FEMALE MIDSECTION	70MM
25001090E	ELEOS MALE-FEMALE MIDSECTION	90MM
25001110E	ELEOS MALE-FEMALE MIDSECTION	110MM
25001140E	ELEOS MALE-FEMALE MIDSECTION	140MM

DISTAL FEMURS

PART NUMBER	DESCRIPTION	SIZE
25000009E	ELEOS DISTAL FEMUR RIGHT, SEGMENTAL	65MM
25000007E	ELEOS DISTAL FEMUR LEFT, SEGMENTAL	65MM

DISTAL FEMUR AXIAL PIN

PART NUMBER	DESCRIPTION	SIZE
25002111E	ELEOS DISTAL FEMUR AXIAL PIN	

TIBIAL HINGE COMPONENTS

PART NUMBER	DESCRIPTION	SIZE
25002100E	ELEOS TIBIAL HINGE COMPONENT W/ ROTATIONAL STOP	
25002101E	ELEOS TIBIAL HINGE COMPONENT W/O ROTATIONAL STOP	

TIBIAL POLY SPACERS

PART NUMBER	DESCRIPTION	SIZE
25001208E	ELEOS TIBIAL POLY SPACER	8MM
25001210E	ELEOS TIBIAL POLY SPACER	10MM
25001212E	ELEOS TIBIAL POLY SPACER	12MM
25001216E	ELEOS TIBIAL POLY SPACER	16MM
25001220E	ELEOS TIBIAL POLY SPACER	20MM

TIBIAL BASEPLATES

PART NUMBER	DESCRIPTION	SIZE
25002201E	ELEOS TIBIAL BASEPLATE SIZE 1	60MM M/L
25002202E	ELEOS TIBIAL BASEPLATE SIZE 2	65MM M/L
25002203E	ELEOS TIBIAL BASEPLATE SIZE 3	70MM M/L
25002204E	ELEOS TIBIAL BASEPLATE SIZE 4	75MM M/L
25002205E	ELEOS TIBIAL BASEPLATE SIZE 5	80MM M/L

STEM EXTENSIONS (CEMENTED)

PART NUMBER	DESCRIPTION	SIZE
KSC01500E	MODULAR TIBIAL BASE STEM CAP	
KSC01530E	ELEOS STEM EXTENSION	15MM X 30MM
KSC01065E	ELEOS STEM EXTENSION	10MM X 65MM
KSC01265E	ELEOS STEM EXTENSION	12MM X 65MM
KSC01465E	ELEOS STEM EXTENSION	14MM X 65MM
KSC01665E	ELEOS STEM EXTENSION	16MM X 65MM
KSC01865E	ELEOS STEM EXTENSION	18MM X 65MM
KSC10100E	ELEOS STEM EXTENSION	10MM X 100MM
KSC12100E	ELEOS STEM EXTENSION	12MM X 100MM
KSC14100E	ELEOS STEM EXTENSION	14MM X 100MM
KSC16100E	ELEOS STEM EXTENSION	16MM X 100MM
KSC18100E	ELEOS STEM EXTENSION	18MM X 100MM

STEM EXTENSIONS (CANAL FILLING)

PART NUMBER	DESCRIPTION	SIZE
KSP10100E	ELEOS STEM EXTENSION	11MM X 100MM
KSP11100E	ELEOS STEM EXTENSION	12MM X 100MM
KSP12100E	ELEOS STEM EXTENSION	13MM X 100MM
KSP13100E	ELEOS STEM EXTENSION	14MM X 100MM
KSP14100E	ELEOS STEM EXTENSION	15MM X 100MM
KSP15100E	ELEOS STEM EXTENSION	16MM X 100MM
KSP16100E	ELEOS STEM EXTENSION	17MM X 100MM
KSP17100E	ELEOS STEM EXTENSION	18MM X 100MM
KSP18100E	ELEOS STEM EXTENSION	19MM X 100MM
KSP20100E	ELEOS STEM EXTENSION	21MM X 100MM
KSP22100E	ELEOS STEM EXTENSION	23MM X 100MM
KSP10140E	ELEOS STEM EXTENSION	11MM X 140MM
KSP11140E	ELEOS STEM EXTENSION	12MM X 140MM
KSP12140E	ELEOS STEM EXTENSION	13MM X 140MM
KSP13140E	ELEOS STEM EXTENSION	14MM X 140MM
KSP14140E	ELEOS STEM EXTENSION	15MM X 140MM
KSP15140E	ELEOS STEM EXTENSION	16MM X 140MM
KSP16140E	ELEOS STEM EXTENSION	17MM X 140MM
KSP17140E	ELEOS STEM EXTENSION	18MM X 140MM
KSP18140E	ELEOS STEM EXTENSION	19MM X 140MM
KSP20140E	ELEOS STEM EXTENSION	21MM X 140MM

RESURFACING PATELLAS

PART NUMBER	DESCRIPTION	SIZE
KPONTP29E	ELEOS RESURFACING PATELLA, ALL-POLY, TRI-PEG	29MM
KPONTP32E	ELEOS RESURFACING PATELLA, ALL-POLY, TRI-PEG	32MM
KPONTP35E	ELEOS RESURFACING PATELLA, ALL-POLY, TRI-PEG	35MM
KPONTP38E	ELEOS RESURFACING PATELLA, ALL-POLY, TRI-PEG	38MM
KPONTP41E	ELEOS RESURFACING PATELLA, ALL-POLY, TRI-PEG	41MM

BLOCK AUGMENTS

PART NUMBER	DESCRIPTION	SIZE
KTAGB105E	ELEOS TIBIAL BLOCK AUGMENT	SIZE 1 X 5MM
KTAGB110E	ELEOS TIBIAL BLOCK AUGMENT	SIZE 1 X 10MM
KTAGB115E	ELEOS TIBIAL BLOCK AUGMENT	SIZE 1 X 15MM
KTAGB205E	ELEOS TIBIAL BLOCK AUGMENT	SIZE 2 X 5MM
KTAGB210E	ELEOS TIBIAL BLOCK AUGMENT	SIZE 2 X 10MM
KTAGB215E	ELEOS TIBIAL BLOCK AUGMENT	SIZE 2 X 15MM
KTAGB305E	ELEOS TIBIAL BLOCK AUGMENT	SIZE 3 X 5MM
KTAGB310E	ELEOS TIBIAL BLOCK AUGMENT	SIZE 3 X 10MM
KTAGB315E	ELEOS TIBIAL BLOCK AUGMENT	SIZE 3 X 15MM
KTAGB405E	ELEOS TIBIAL BLOCK AUGMENT	SIZE 4 X 5MM
KTAGB410E	ELEOS TIBIAL BLOCK AUGMENT	SIZE 4 X 10MM
KTAGB415E	ELEOS TIBIAL BLOCK AUGMENT	SIZE 4 X 15MM
KTAGB505E	ELEOS TIBIAL BLOCK AUGMENT	SIZE 5 X 5MM
KTAGB510E	ELEOS TIBIAL BLOCK AUGMENT	SIZE 5 X 10MM
KTAGB515E	ELEOS TIBIAL BLOCK AUGMENT	SIZE 5 X 15MM

INSTRUMENTS

REAMERS

PART NUMBER	DESCRIPTION	SIZE
K0051010E	CYLINDRICAL REAMER	10MM
K0050510E	CYLINDRICAL REAMER	10.5MM
K0051011E	CYLINDRICAL REAMER	11MM
K0050511E	CYLINDRICAL REAMER	11.5MM
K0051012E	CYLINDRICAL REAMER	12MM
K0050512E	CYLINDRICAL REAMER	12.5MM
K0051013E	CYLINDRICAL REAMER	13MM
K0050513E	CYLINDRICAL REAMER	13.5MM
K0051014E	CYLINDRICAL REAMER	14MM
K0050514E	CYLINDRICAL REAMER	14.5MM
K0051015E	CYLINDRICAL REAMER	15MM
K0050515E	CYLINDRICAL REAMER	15.5MM
K0051016E	CYLINDRICAL REAMER	16MM
K0050516E	CYLINDRICAL REAMER	16.5MM
K0051017E	CYLINDRICAL REAMER	17MM
K0050517E	CYLINDRICAL REAMER	17.5MM
K0051018E	CYLINDRICAL REAMER	18MM
K0050518E	CYLINDRICAL REAMER	18.5MM
K0051019E	CYLINDRICAL REAMER	19MM
K0050519E	CYLINDRICAL REAMER	19.5MM
K0051020E	CYLINDRICAL REAMER	20MM
K0050520E	CYLINDRICAL REAMER	20.5MM
K0051021E	CYLINDRICAL REAMER	21MM
K0050521E	CYLINDRICAL REAMER	21.5MM
K0051022E	CYLINDRICAL REAMER	22MM
K0050522E	CYLINDRICAL REAMER	22.5MM
K0051023E	CYLINDRICAL REAMER	23MM
K0051116E	STABILIZING COLLET	16MM
K0051118E	STABILIZING COLLET	18MM
K0051120E	STABILIZING COLLET	20MM
K0051122E	STABILIZING COLLET	22MM
K0051124E	STABILIZING COLLET	24MM
001-03-00001	REAMERS (TRAY 1)	
001-03-00016	TRAY LID STANDARD	

ASSEMBLY/DISASSEMBLY INSTRUMENTS

PART NUMBER	DESCRIPTION	SIZE
18041000E	SLAP HAMMER EXTRACTOR HANDLE	
25100008E	TIBIAL BASEPLATE ASSEMBLY PLATFORM	
25107000E	TAPER DISASSEMBLY TOOL	
25107001E	TAPER DISASSEMBLY FORK	
25107101E	FEMORAL ASSEMBLY PLATFORM	
25107500E	MIDSECTION ASSEMBLY IMPACTOR	
25107501E	STEM ASSEMBLY IMPACTOR	
25107600E	FEMORAL IMPACTOR	
25107601E	DISTAL FEMORAL EXTRACTOR	
25107602E	TIBIAL IMPACTOR	
001-03-00002	ASSEMBLY/DISASSEMBLY INSTRUMENTS (TRAY 2)	
001-03-00016	TRAY LID STANDARD	

SEGMENTAL STEM TRIALS

PART NUMBER	DESCRIPTION	SIZE
25100011E	TRIAL SEGMENTAL STEM	11MM X 152MM
25100013E	TRIAL SEGMENTAL STEM	13MM X 152MM
25100015E	TRIAL SEGMENTAL STEM	15MM X 152MM
25100017E	TRIAL SEGMENTAL STEM	17MM X 152MM
SPSETB11E	TRIAL SEGMENTAL STEM	11MM X 152MM
SPSETB13E	TRIAL SEGMENTAL STEM	13MM X 152MM
SPSETB15E	TRIAL SEGMENTAL STEM	15MM X 152MM
SPSETB17E	TRIAL SEGMENTAL STEM	17MM X 152MM
25104009E	TRIAL SEGMENTAL STEM	9MM X 120MM
25104011E	TRIAL SEGMENTAL STEM	11MM X 120MM
25104013E	TRIAL SEGMENTAL STEM	13MM X 120MM
25107400E	STEM EXTRACTOR ATTACHMENT	
25107201E	UNIVERSAL RESECTION PLANER	
25107207E	RESECTION PLANER	7MM
25107209E	RESECTION PLANER	9MM
25107211E	RESECTION PLANER	11MM
20040110E	PILOT POINT #10	
20040111E	PILOT POINT #11	
20040112E	PILOT POINT #12	
20040113E	PILOT POINT #13	
20040114E	PILOT POINT #14	
20040115E	PILOT POINT #15	
001-03-00003	SEGMENTAL STEM TRIALS (TRAY 3)	
001-03-00016	TRAY LID STANDARD	

PROXIMAL/DISTAL FEMORAL SEGMENTAL TRIALS

PART NUMBER	DESCRIPTION	SIZE
18052205E	TRIAL FEMORAL HEAD	22MM
18052206E	TRIAL FEMORAL HEAD	22MM
18056007E	TRIAL FEMORAL HEAD	32MM
18056008E	TRIAL FEMORAL HEAD	32MM
18056009E	TRIAL FEMORAL HEAD	32MM
18056010E	TRIAL FEMORAL HEAD	32MM
18056020E	TRIAL FEMORAL HEAD	36MM
18056021E	TRIAL FEMORAL HEAD	36MM
18056022E	TRIAL FEMORAL HEAD	36MM
18056023E	TRIAL FEMORAL HEAD	36MM
18056050E	TRIAL FEMORAL HEAD	28MM
18056051E	TRIAL FEMORAL HEAD	28MM
18056052E	TRIAL FEMORAL HEAD	28MM
18056053E	TRIAL FEMORAL HEAD	28MM
18056054E	TRIAL FEMORAL HEAD	28MM
18080279E	PROXIMAL FEMUR IMPACTOR	
18810211E	UNIVERSAL IMPACTOR	
25100001E	TRIAL PROXIMAL FEMUR	
25100003E	TRIAL DISTAL FEMUR	
25100005E	TRIAL DISTAL FEMUR	
25100040E	TRIAL MALE-FEMALE MIDSECTION	40MM
25100050E	TRIAL MALE-FEMALE MIDSECTION	50MM
25100060E	TRIAL MALE-FEMALE MIDSECTION	60MM
25100070E	TRIAL MALE-FEMALE MIDSECTION	70MM
25100090E	TRIAL MALE-FEMALE MIDSECTION	90MM
25100110E	TRIAL MALE-FEMALE MIDSECTION	110MM
25100140E	TRIAL MALE-FEMALE MIDSECTION	140MM
25102113E	TRIAL AXIAL PIN	
25107502E	PROXIMAL FEMORAL RESECTION TEMPLATE	
25107504E	DISTAL FEMORAL RESECTION TEMPLATE	
001-03-00004	PROXIMAL DISTAL FEMORAL SEGMENTAL TRIALS (TRAY 4)	
001-03-00016	TRAY LID STANDARD	

STEM EXTENSION TRIALS

PART NUMBER	DESCRIPTION	SIZE
K0050010E	TRIAL STEM EXTENSION	10MM X 100MM
K0050011E	TRIAL STEM EXTENSION	11MM X 100MM
K0050012E	TRIAL STEM EXTENSION	12MM X 100MM
K0050013E	TRIAL STEM EXTENSION	13MM X 100MM
K0050014E	TRIAL STEM EXTENSION	14MM X 100MM
K0050015E	TRIAL STEM EXTENSION	15MM X 100MM
K0050016E	TRIAL STEM EXTENSION	16MM X 100MM
K0050017E	TRIAL STEM EXTENSION	17MM X 100MM
K0050018E	TRIAL STEM EXTENSION	18MM X 100MM
K0050020E	TRIAL STEM EXTENSION	20MM X 100MM
K0050022E	TRIAL STEM EXTENSION	22MM X 100MM
K0051005E	STEM IMPLANT EXTRACTOR-ADAPTOR	
K0051410E	TRIAL STEM EXTENSION	10MM X 140MM
K0051411E	TRIAL STEM EXTENSION	11MM X 140MM
K0051412E	TRIAL STEM EXTENSION	12MM X 140MM

ELEOS Limb Salvage System

K0051413E	TRIAL STEM EXTENSION	13MM X 140MM
K0051414E	TRIAL STEM EXTENSION	14MM X 140MM
K0051415E	TRIAL STEM EXTENSION	15MM X 140MM
K0051416E	TRIAL STEM EXTENSION	16MM X 140MM
K0051417E	TRIAL STEM EXTENSION	17MM X 140MM
K0051418E	TRIAL STEM EXTENSION	18MM X 140MM
K0051420E	TRIAL STEM EXTENSION	20MM X 140MM
K0051530E	TRIAL STEM EXTENSION	15MM X 30MM
K0056510E	TRIAL STEM EXTENSION	10MM X 65MM
K0056512E	TRIAL STEM EXTENSION	12MM X 65MM
K0056514E	TRIAL STEM EXTENSION	14MM X 65MM
K0056516E	TRIAL STEM EXTENSION	16MM X 65MM
K0056518E	TRIAL STEM EXTENSION	18MM X 65MM
001-03-00005	STEM EXTENSION TRIALS (TRAY 5)	
001-03-00016	TRAY LID STANDARD	

TIBIAL RESURFACING TRIALS

PART NUMBER	DESCRIPTION	SIZE
25101208E	TRIAL TIBIAL POLY SPACER	8MM
25101210E	TRIAL TIBIAL POLY SPACER	10MM
25101212E	TRIAL TIBIAL POLY SPACER	12MM
25101216E	TRIAL TIBIAL POLY SPACER	16MM
25101220E	TRIAL TIBIAL POLY SPACER	20MM
25102100E	TRIAL TIBIAL HINGE COMPONENT	
25102301E	TRIAL TIBIAL BASEPLATE	SIZE 1
25102302E	TRIAL TIBIAL BASEPLATE	SIZE 2
25102303E	TRIAL TIBIAL BASEPLATE	SIZE 3
25102304E	TRIAL TIBIAL BASEPLATE	SIZE 4
25102305E	TRIAL TIBIAL BASEPLATE	SIZE 5
001-03-00006	TIBIAL RESURFACING TRIALS (TRAY 6)	
001-03-00015	TRAY LID SMALL	

TIBIAL RESURFACING PREPARATION INSTRUMENTS

PART NUMBER	DESCRIPTION	SIZE
18410135E	SCREWDRIVER	
25107104E	PRESS FIT REAMER GUIDE	
25107105E	CEMENTED REAMER GUIDE	
25107110E	KEEL PUNCH GUIDE	
2510SL10E	TRIAL TIBIAL BASEPLATE TEMPLATE	SIZE 1
2510SL20E	TRIAL TIBIAL BASEPLATE TEMPLATE	SIZE 2
2510SL30E	TRIAL TIBIAL BASEPLATE TEMPLATE	SIZE 3
2510SL40E	TRIAL TIBIAL BASEPLATE TEMPLATE	SIZE 4
2510SL50E	TRIAL TIBIAL BASEPLATE TEMPLATE	SIZE 5
K0001112E	KEEL PUNCH IMPACTOR	
K0020211E	DEPTH STYLUS 2MM / 10MM	
K0021012E	TRIAL TIBIAL BASE HANDLE / DRILL GUIDE	
K0027101E	KEEL PUNCH GUIDE HANDLE	
K0040040E	VARUS/VALGUS TIBIAL RESECTION GUIDE	
K0041000E	IM TIBIAL ALIGNMENT GUIDE	
K0041010E	IM TIBIAL RESECTION GUIDE	
K0050001E	PRESS FIT KEEL PUNCH SIZE 1, 1+, & 2	

ELEOS Limb Salvage System

K0050002E	CEMENTED KEEL PUNCH SIZE 1, 1+, & 2
001-03-00007	TIBIAL RESURFACING PREPARATION INSTRUMENTS (TRAY 7)
001-03-00016	TRAY LID STANDARD

GENERAL RESURFACING INSTRUMENTS

PART NUMBER	DESCRIPTION	SIZE
18055001E	UNIVERSAL HUDSON ADAPTOR	
25102211E	AXIAL PIN INSERTER/ EXTRACTOR	
25107613E	TIBIAL BASEPLATE PRESS FIT REAMER	
25107614E	TIBIAL BASEPLATE CEMENTED REAMER	
K0000900E	EXTERNAL CHECK GUIDE	
K0000901E	EXTERNAL CHECK ROD	
K0001002E	STARTER DRILL BIT 3/8 IN	
K0001005E	DRILL BIT 1/8 IN	
K0001006E	QUICK DISCONNECT FOR 1/8" DRILL BIT	
K0001015E	DRILL BIT 1/8IN X 100MM	
K0001016E	QUICK DISCONNECT T-HANDLE	
K0001101E	11 IN REAMER/IM ROD	
K0002007E	TIBIAL BASEPLATE FIXATION PIN	
K0002008E	SLAP HAMMER PIN EXTRACTOR	
K0002010E	PIN PULLER	
K0002011E	FIXATION PIN, HEADLESS	80MM
K0002015E	PIN INSERTER	
K0014407E	DUAL REFERENCE GAUGE	
001-03-00014	PIN CADDY	
001-03-00008	GENERAL RESURFACING INSTRUMENTS (TRAY 8)	
001-03-00016	TRAY LID STANDARD	

PATELLA INSTRUMENTS

PART NUMBER	DESCRIPTION	SIZE
18410213E	PATELLA/FEMORAL HEAD SIZING CALIPER	
18810210E	RESURFACING PATELLA RESECTION GAUGE	10MM
18810220E	RESURFACING PATELLA RESECTION GUIDE	
18810228E	RESURFACING PATELLA DEPTH GAUGE	8MM
18811210E	RESURFACING PATELLA MINIMUM THICKNESS GAUGE	10MM
18811215E	RESURFACING PATELLA MINIMUM THICKNESS GAUGE	15MM
18812211E	RESURFACING PATELLA THICKNESS RESECTION GAUGE	11MM
K0031000E	PATELLA CLAMP	
K0031001E	PATELLA CLAMP SEATER	
K0031002E	RESURFACING PATELLA PEG DRILL GUIDE	
K0031013E	RESURFACING PATELLA PEG DRILL	
KPTRTP32E	TRIAL RESURFACING PATELLA	32MM
KPTRTP35E	TRIAL RESURFACING PATELLA	35MM
KPTRTP38E	TRIAL RESURFACING PATELLA	38MM
KPTRTP41E	TRIAL RESURFACING PATELLA	41MM
001-03-00010	PATELLA INSTRUMENTS (TRAY 10)	
001-03-00016	TRAY LID STANDARD	

AUGMENT PREPARATION & TRIALING INSTRUMENTS

PART NUMBER	DESCRIPTION	SIZE
K0052002E	REVISION BLOCK AUGMENT RESECTION GUIDE	
K0052003E	REVISION BLOCK AUGMENT RESECTION GUIDE	
K0053013E	TRIAL BLOCK AUGMENT 5MM	SIZE 1
K0053014E	TRIAL BLOCK AUGMENT 5MM	SIZE 1
K0053015E	TRIAL BLOCK AUGMENT 5MM	SIZE 2
K0053016E	TRIAL BLOCK AUGMENT 5MM	SIZE 2
K0053017E	TRIAL BLOCK AUGMENT 5MM	SIZE 3
K0053018E	TRIAL BLOCK AUGMENT 5MM	SIZE 3
K0053019E	TRIAL BLOCK AUGMENT 5MM	SIZE 4
K0053020E	TRIAL BLOCK AUGMENT 5MM	SIZE 4
K0053021E	TRIAL BLOCK AUGMENT 5MM	SIZE 5
K0053022E	TRIAL BLOCK AUGMENT 5MM	SIZE 5
K0053025E	TRIAL BLOCK AUGMENT 10MM	SIZE 1
K0053026E	TRIAL BLOCK AUGMENT 10MM	SIZE 1
K0053027E	TRIAL BLOCK AUGMENT 10MM	SIZE 2
K0053028E	TRIAL BLOCK AUGMENT 10MM	SIZE 2
K0053029E	TRIAL BLOCK AUGMENT 10MM	SIZE 3
K0053030E	TRIAL BLOCK AUGMENT 10MM	SIZE 3
K0053031E	TRIAL BLOCK AUGMENT 10MM	SIZE 4
K0053032E	TRIAL BLOCK AUGMENT 10MM	SIZE 4
K0053033E	TRIAL BLOCK AUGMENT 10MM	SIZE 5
K0053034E	TRIAL BLOCK AUGMENT 10MM	SIZE 5
K0053037E	TRIAL BLOCK AUGMENT 15MM	SIZE 1
K0053038E	TRIAL BLOCK AUGMENT 15MM	SIZE 1
K0053039E	TRIAL BLOCK AUGMENT 15MM	SIZE 2
K0053040E	TRIAL BLOCK AUGMENT 15MM	SIZE 2
K0053041E	TRIAL BLOCK AUGMENT 15MM	SIZE 3
K0053042E	TRIAL BLOCK AUGMENT 15MM	SIZE 3
K0053043E	TRIAL BLOCK AUGMENT 15MM	SIZE 4
K0053044E	TRIAL BLOCK AUGMENT 15MM	SIZE 4
K0053045E	TRIAL BLOCK AUGMENT 15MM	SIZE 5
K0053046E	TRIAL BLOCK AUGMENT 15MM	SIZE 5
001-03-00013	AUGMENT PREPARATION AND TRIALING INSTRUMENTS (TRAY 13)	
001-03-00016	TRAY LID STANDARD	

X-RAY TEMPLATES

PART NUMBER	DESCRIPTION	SIZE
G015XRGSE	X-RAY TEMPLATES	

ELEOS Limb Salvage System

The ELEOS Limb Salvage System is compatible with the following MicroPort Orthopedics systems trademarked by MicroPort: Guardian, Advance, Gladiator, Lineage, and Transcend.

ELEOS and Onkos are trademarks of Onkos Surgical.

©2017, Onkos Surgical. All Rights Reserved.

ELSS DF.12.13.16 v0

Onkos Surgical

77 East Halsey Road

Parsippany, NJ 07054

973.264.5400

www.onkossurgical.com/ELEOS