

ELEOS™ Limb Salvage System

Surgical Technique
Proximal Tibia Replacement



The ELEOS Limb Salvage System offers options for patients with significant bone loss due to cancer, trauma, or previous surgical procedures. The locking taper design has a history of clinical use in a variety of orthopaedic applications. With an array of options in a multitude of sizes, the ELEOS System provides the surgeon the ability to meet a variety of patient needs.

 ONKOS SURGICAL™



ELEOS Limb Salvage System

PROXIMAL TIBIA REPLACEMENT

TABLE OF CONTENTS:

PRODUCT DESCRIPTION

SURGICAL TECHNIQUE STEPS

FEMORAL PREPARATION

- FEMORAL REAMING
- DISTAL FEMORAL ALIGNMENT
- DISTAL FEMORAL RESECTION
- FEMORAL SIZING
- ANTERIOR AND POSTERIOR RESECTIONS
- RESURFACING FEMUR TRIALING

TIBIAL PREPARATION

- TIBIAL RESECTION
- TIBIAL PLANING
- TIBIAL REAMING
- TRIAL ASSEMBLY
- TRIAL REDUCTION

COMPONENT ASSEMBLY

- FEMORAL COMPONENT
- TIBIAL COMPONENT

PREPARATION OF CEMENT

COMPONENT INSERTION

- FEMORAL COMPONENT
- TIBIAL COMPONENT
- TIBIAL HINGE ASSEMBLY

PATELLA RECONSTRUCTION (OPTIONAL)

COMPONENT DISSASSEMBLY

EXPLANTATION INFORMATION

IMPLANT PART NUMBERS

INSTRUMENT PART NUMBERS

Proper surgical procedures and techniques are the responsibility of the medical professional. The following guidelines are furnished for informational purposes only. Each surgeon must evaluate the appropriateness of the procedures based on his or her personal medical training, experience and patient condition. Prior to the use of the system, the surgeon should refer to the product package insert for additional warnings, precautions, indications, contraindications and adverse effects. Instruction for use package inserts are available at www.onkossurgical.com/ELEOS/IFU.

PRODUCT DESCRIPTION

The ELEOS Proximal Tibia System consists of eight components that create a hinged knee: the Resurfacing Femur, Stem Extension, Tibial Hinge Baseplate, Axial Pin, Proximal Tibia Component, Optional Midsection, Tibial Polyethylene Spacer, and Segmental Stem. Additional midsections can be added if more length is required.

NOTE | A Cemented Resurfacing Patella and Wedge and Block Augments are available if needed.

The Resurfacing Femur (2500(X)00(X)E) features a deepened patellar groove and a 5° valgus angle to assist in the restoration of patello-femoral kinematics, reduction of patellar subluxation and promotion of normal loading patterns. Internal/external rotation of the hinge can be controlled with a component that has a stop set for +/- 15° or a hinge component without a stop can be used. The Resurfacing Femur is available in three sizes for intraoperative flexibility.

The Proximal Tibia (25002200E) is available in one size. The Proximal Tibia profile has been minimized to aid in soft tissue closure. The Tibial Poly Spacer (250012(XX)E) is available in 8mm, 10m, 12mm, 16mm and 20mm thicknesses and accommodates a 120mm or 152mm length Segmental Stem. Seven lengths of optional Midsection (25001(XX)0E) components are interchangeable with all ELEOS systems to allow for precise length determination intraoperatively. Lengths ranging from 40-140mm accommodate bone resection in 10 mm increments.

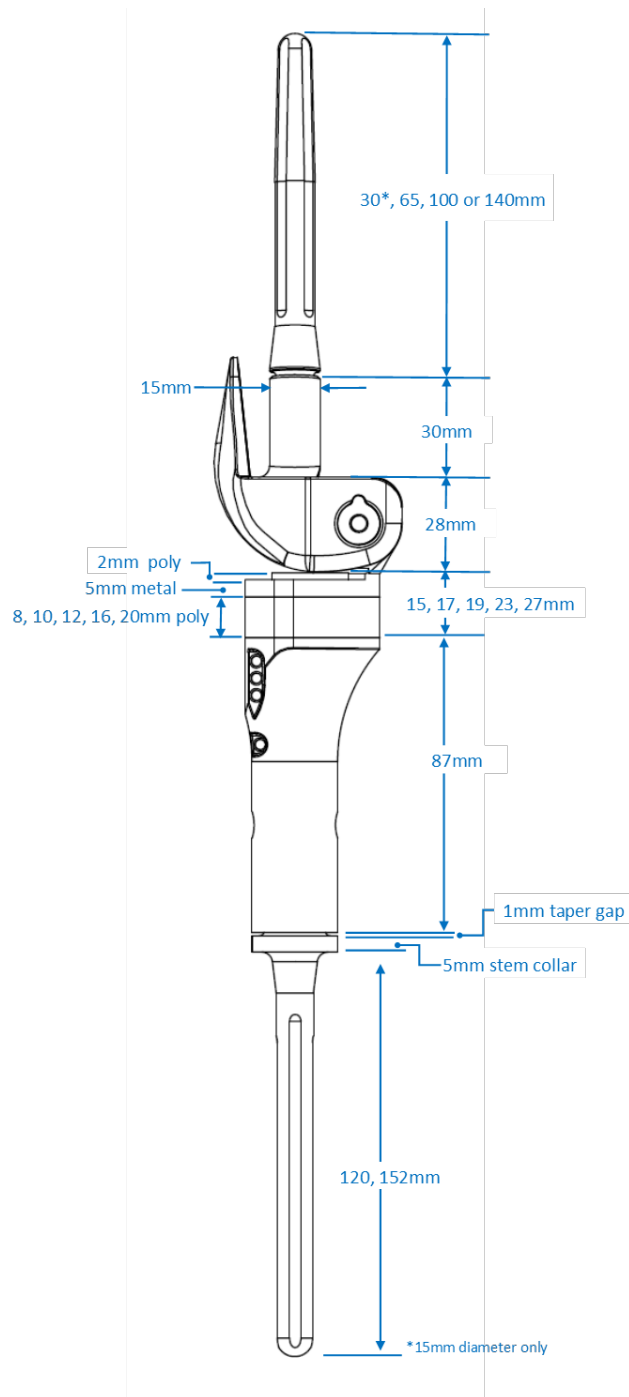

COMPONENT	RESECTION
Femoral Resection	28mm
Tibial Resection	108mm*

* With an 8mm polyethylene spacer and hinge mechanism

The Resurfacing Femur accepts cemented or canal filling Stem Extensions in a variety of lengths and diameters | **Table 1.**

Table 1.

Stem Extensions – Cemented				
Stem	Description	Length	Diameter	Collar
KSC01530E	Straight Cylindrical, Fluted, Titanium (bullet tip)	30mm	15mm	None
KSC0(XX)65E	Straight Cylindrical, Fluted, Titanium	65mm	10, 12, 14, 16,18mm	None
KSC(XX)100E	Straight Cylindrical, Fluted, Titanium	100mm	10, 12, 14, 16, 18mm	None
Stem Extensions – Canal Filling				
Stem	Description	Length	Diameter	Collar
KSP(XX)100E	Straight, Cylindrical Splined, Slotted, Titanium	100mm	11, 12, 13, 14, 15, 16, 17, 18, 19, 21, 23mm	None
KSP(XX)140E	Straight, Cylindrical Splined, Slotted, Titanium	140mm	11, 12, 13, 14, 15, 16, 17, 18, 19, 21mm	None

Segmental Stems are available in a variety of lengths and diameters in both cemented and canal filling options. Cemented Stems provide flutes to enhance mechanical interlock of bone cement. Canal filling stems are spline and slotted (152mm only) and have plasma spray to enhance initial fixation | **Table 2.**

Table 2.

Segmental Stems – Cemented				
Stem	Description	Length	Diameter	Collar
250000(XX)E	Straight Cylindrical, Fluted, Titanium	152mm	11, 13mm	25mm
2500CC(XX)E	Straight Cylindrical, Fluted, Titanium	152mm	15, 17mm	32mm
250040(XX)E	Straight, Cylindrical, Fluted, Cobalt Chrome	120mm	9, 11, 13mm	25mm
Segmental Stems – Canal Filling				
Stem	Description	Length	Diameter	Collar
SPSE00(XX)E	152mm, Straight, Cylindrical, Splined, Slotted, Titanium w/ Plasma Spray 2/3	152mm	12, 14, 16, 18mm	25mm
2500CP(XX)E	Straight, Cylindrical, Splined, Slotted, Titanium w/ Plasma Spray 2/3	152mm	12, 14, 16mm	32mm
2500SP(XX)E	Straight, Cylindrical, Splined, Full Plasma Spray, Titanium	120mm	12, 14, 16mm	25mm
2500SP(XX)E	Straight, Cylindrical, Splined, Full Plasma Spray, Titanium	120mm	18, 20, 22mm	32mm

*Tapers down 2mm

SURGICAL TECHNIQUE STEPS

FEMORAL PREPARATION

NOTE | Following tumor resection, it is surgeon preference if the femoral resection or tibial resection is done first.



Figure 1.

FEMORAL REAMING

Initiate an opening in the femoral canal with the Starter Drill Bit 3/8 in. The entry point is placed medial and anterior to the anteromedial corner of the intercondylar notch.

NOTE | Hand reaming may be appropriate to avoid a thin femoral cortex that could result in a fracture. Care should be taken if reaming with power

A preliminary reaming process is initiated to establish the anatomic axis of the distal femur. Begin incrementally reaming with the 10mm or appropriate sized Cylindrical Reamer | **FIGURE 1**. Reamers are available in diameters from 10-23mm in 1/2mm increments and are marked at 65, 100, and 140mm lengths **A IN | FIGURE 2**.

NOTE | The markings on the Reamer account for the additional material of the Resurfacing Femur (implant thickness and boss length). Therefore, a 65mm mark corresponds to an actual depth of 115mm, and a 100mm mark corresponds to an actual depth of 150mm length, and a 140mm mark to a depth of 190mm. If the distal resection is made as would be in a revision scenario, reaming to this line will extend past the distal end of the stem extension

NOTE | The Stem Extension diameters from Table 1 are equal to Reamer diameters. When determining the appropriate Cylindrical Reamer size for the desired cement mantle, the difference will represent the cement mantle. For instance, reaming to a 13mm diameter will provide a line-to-line fit with a 13mm stem. Reaming to a 14mm will provide a 0.5mm cement mantle per side, while reaming to 15mm will provide a 1mm cement mantle per side.

Make sure to ream in an elliptical fashion with the first few reamers to ensure the distal bone does not dictate the path of the reamer.

CAUTION | During the reaming process, the intramedullary canal of the femur should be repeatedly irrigated and aspirated to reduce the chance of fat emboli.

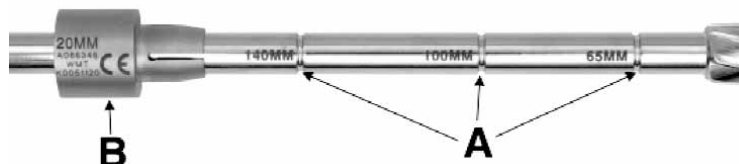

Figure 2.



Figure 3.

With desired reaming complete, ensure the Reamer provides a stable construct for additional femoral preparation. If additional stability is required due to a large opening at the distal femur, Stabilizing Collets are available in 16, 18, 20, 22, and 24mm diameters **B IN | FIGURE 2**. Place the appropriate size Stabilizing Collet over the reamer shank, proximal to the distal surface of the femur **| FIGURE 3**.

Ensure that the Stabilizing Collet is recessed below the planed level of distal femoral resection so that the Valgus Angle Alignment Guide can be seated flush to the distal surface.

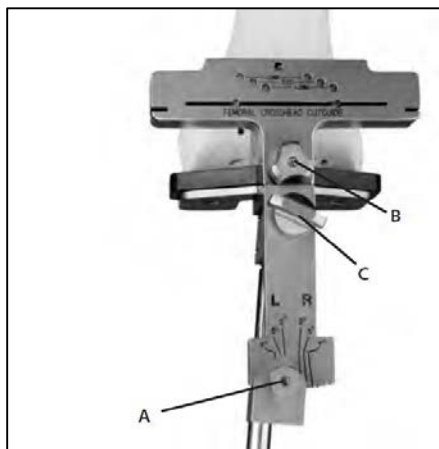

Figure 4.

DISTAL FEMORAL ALIGNMENT

The Valgus Angle Alignment Guide should be set at 5° (left or right) to match the 5° valgus orientation of the Resurfacing Femur. Set the valgus angle to 5° and tighten the small thumb screw **A IN | FIGURE 4**. Attach the Distal Femoral Resection Guide by fully seating it to the Valgus Angle Alignment Guide and tighten the small screw by hand or with a screwdriver **B IN | FIGURE 4**. Slide the entire construct over the fixed Cylindrical Reamer and lock the guide to the reamer by tightening the large thumb screw after the guide touches the most prominent condyle surface from the joint line **C IN | FIGURE 4**.

DISTAL FEMORAL RESECTION

NOTE | All femoral resection slots are designed for use with a .050" (1.3mm) thick saw blade. The distal femoral resection depth can be adjusted using the 9mm spacer between the platform of the Valgus Angle Alignment Guide and the most proximal condyle if a femoral component was removed in a revision situation | **FIGURE 5.**

The 9mm Femoral Distal Spacer accounts for the distal thickness of a primary femoral implant that was removed. Once assembled, the spacer will provide a 28mm resection along the most prominent condyle surface from the joint line.



Figure 5.

A secondary check is available by referencing the small slots on the Distal Femoral Resection Guide. By matching the position of these slots to the transepicondylar axis, a theoretical placement of the original joint line is indicated | **FIGURE 6.**

CAUTION | Placing the Valgus Angle Alignment Guide paddles **A IN | FIGURE 6**, or the 9mm spacer if present, flush against the resected distal surface will result in a 28mm distal resection from the joint line (where the paddles touch the femur).

With the guide properly positioned, pin the Distal Femoral Resection Guide by placing 1/8" (3.2mm) Headless Fixation Pins or Drill Bits into the holes marked "STD" **A | IN FIGURE 7**. The distal femoral resection can be performed with or without the Reamer and Valgus Angle Alignment Guide in place. If the guide is left, take caution to avoid the IM reamer while making the resection. To remove the guide, loosen both thumb screws **B IN | FIGURE 7** and disengage the Valgus Angle Alignment Guide from the Distal Femoral Resection Guide. Utilize the Quick Disconnect T-handle to remove the reamer. A distal resection is performed through the resection slot **C IN | FIGURE 7**.

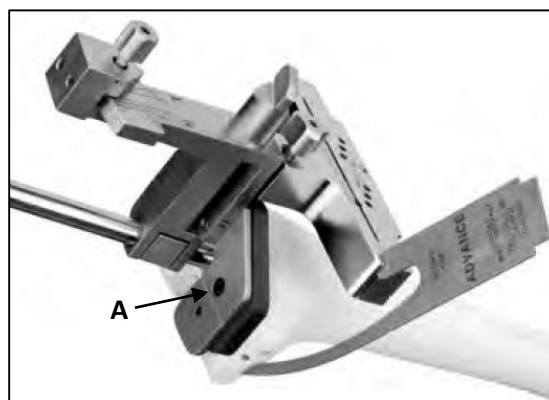

Figure 6.

After the resection is complete, remove the Distal Femoral Resection Guide and pins from the bone.

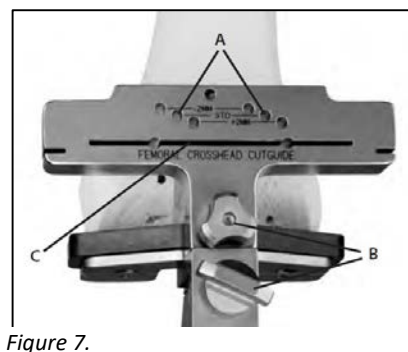

Figure 7.

FEMORAL SIZING

Femoral implant sizing can be approximated by one of the following methods:

- 1 | Use of trial femoral components
- 2 | Pre-operative radiographic evaluation of both knees.

ANTERIOR AND POSTERIOR RESECTIONS

If the Cylindrical Reamer was removed to make the distal resection, the Reamer needs to be inserted again to accommodate attachment of the Femoral A/P Resection Guide.

Select the Femoral A/P Resection Guide corresponding to the size Resurfacing Femur previously determined. Assemble the 5° IM Revision Angle Locator with the correct "Left" or "Right" marking facing the arrow on the Femoral A/P Resection Guide **A IN | FIGURE 8** and place the entire assembly over the fixed Cylindrical Reamer. Two laser marks on the face of the block indicate the M-L width of the Resurfacing Femur for a final check of femoral sizing **B IN | FIGURE 8**.

External rotation can be set by referencing either the medial and lateral epicondyles (transepicondylar axis) or A/P axis of the femur (perpendicular plane to the patella groove). After rotation is established, fully seat the A/P resection guide on the distal femoral resection. Tighten the thumbscrew **C IN | FIGURE 8** and stabilize the block using fixation pins on the medial and lateral sides of the block. The fixation holes can be predrilled with a 1/8in Drill Bit. Femoral resections are performed through the anterior and posterior resection slots. The anterior femoral resection is 6° divergent to the posterior resection.

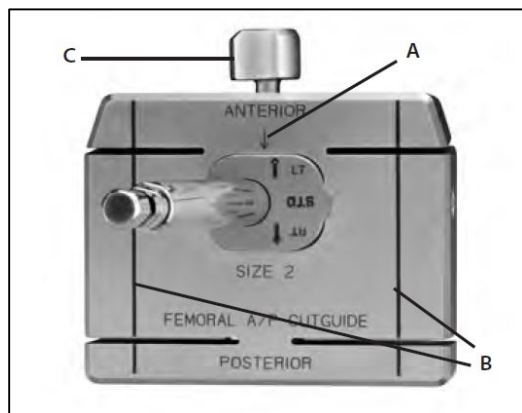

Figure 8.

RESURFACING FEMUR TRIALING

Assemble the appropriate size Trial Stem Extension to the Trial Resurfacing Femur. Using the Femoral Impactor, impact the Trial Resurfacing Femur onto the prepared bone | **FIGURE 9.**



Figure 9.

TIBIAL PREPARATION

TIBIAL RESECTION

CAUTION | A full x-ray and/or 3-dimensional image or CT must be reviewed prior to surgery to ensure adequate bone stock is available for resection and proper reaming.

Determine the amount of tibial bone to be resected while noting x-ray magnification. Resect the minimal amount of bone that conforms to implant availability. The amount of bone to be resected is determined by clinical evaluation. To determine the midsection and stem to use, consult | **TABLE 3.**

Using an available ruler or the trial construct needed, measure the level of resection from the proximal tibia. Mark the level of resection | **FIGURE 10.**



Figure 10.

Table 3.

PROXIMAL TIBIA RESECTION

Part Number	Component	Resection*
N/A	No Midsection	108mm
25001040E	40mm	149mm
25001050E	50mm	159mm
25001060E	60mm	169mm

* Tibia resection measured from top of bumpers on the tibial hinge base to the level of the tibial resection with an 8mm polyethylene spacer

Resect the proximal tibia at the marked location, making a transverse cut | **FIGURE 11.**



Figure 11.

TIBIAL PLANING

There are three Resection Planers available (7mm, 9mm, and 11mm diameter pilots). Plane the resected surface using the planer that best fits the diameter of the intramedullary canal at the resection level | **FIGURE 12.**

TIBIAL REAMING

Ream the tibial canal using Cylindrical Reamers if a cylindrical stem is to be implanted. Ream to a depth of 120mm or 152mm depending on the segmented stem chosen | **FIGURE 13.** Select a stem diameter that corresponds to the appropriate cement mantle based on clinical evaluation | **TABLE 2.**

NOTE | The Segmental Stem diameters from Table 2 are equal to Reamer diameters. When determining the appropriate Cylindrical Reamer size for the desired cement mantle, the difference will represent the cement mantle. For instance, reaming to a 13mm diameter will provide a line-to-line fit with a 13mm stem. Reaming to a 14mm will provide a 0.5mm cement mantle per side, while reaming to 15mm will provide a 1mm cement mantle per side.

NOTE | The markings on the reamer account for the additional material of the resurfacing femur (implant thickness and boss length). Therefore, a 65mm mark corresponds to an actual depth of 115mm, and a 100mm mark corresponds to an actual depth of 150mm length, and a 140mm mark to a depth of 190mm.



Figure 12.



Figure 13.

TRIAL ASSEMBLY

Assemble the Trial Proximal Tibia, Midsection (optional), Segmental Stem Trial, Trial Tibial Poly Spacer, Trial Tibial Hinge Component and Trial Axial Pin | **FIGURES 14-17.**

TRIAL REDUCTION

Perform a trial reduction. If the soft tissues require adjustment, minor changes can be accomplished by selecting alternate Tibial Poly Spacers. More significant adjustments may require changing the resection level.

NOTE | Final tibial rotation can be set by marking the bone to match up with the stem match mark.



Figure 14.



Figure 15.



Figure 16.



Figure 17.

COMPONENT ASSEMBLY

FEMORAL COMPONENT

On the back table, place the Resurfacing Femur and Stem Extension in the assembly fixture using the Trial Axial Pin, and assemble with five hard mallet blows using the Stem Assembly Impactor | **FIGURE 18.**

NOTE | Utilize the match mark on the Stem Extension so that the slot accommodates the bow of the femur.

TIBIAL COMPONENT

Place the Proximal Tibia on the Tibial Baseplate Assembly Platform. Assemble the Segmental Stem and Midsection, if needed, onto the Proximal Tibia using five hard mallet blows with the Stem Assembly Impactor directly on the tip of the stem | **FIGURE 19.**



Figure 18.



Figure 19.

PREPARATION OF CEMENT

Cement mixing begins and the femoral and tibial canals are cleaned using pulsating lavage and then dried with a femoral sponge or tampon. If desired, a cement restrictor (plug) can be placed in the canal. Cement is injected in a pressurized retrograde fashion.

COMPONENT INSERTION



Figure 20.

FEMORAL COMPONENT

Place the resurfacing femur Stem Extension in the femoral canal. Guide and impact the Resurfacing Femur into the canal with the Femoral Impactor until the implant is seated | **FIGURE 20.**

Remove excess cement. Final position of the implant should be maintained until the cement cures.



Figure 21.

TIBIAL COMPONENT

Place the Proximal Tibia and Tibial Polyethylene Spacer into the canal using the Tibial Impactor | **FIGURE 21.**

CAUTION | Care should be taken to maintain the final components in the appropriate position until the cement has set fully. **NOTE** | Align the stem match mark to the marking on bone made earlier to obtain proper rotational alignment as planned for during trialing.

TIBIAL HINGE ASSEMBLY

Insert the tibial portion of the Tibial Hinge Component assembly into the tibia | **FIGURE 22.**
Align the Resurfacing Femur with the Tibial Hinge | **FIGURE 23.**



Figure 22.



Figure 23.

Insert the Axial Pin using the Axial Pin Inserter/Extractor instrument | **FIGURES 24-26.**



Figure 24.



Figure 25.



Figure 26.



Figure 27.

The Axial Pin can be inserted either on the medial or lateral side. The Axial Pin key must fall into the corresponding pocket in the Resurfacing Femur. Make sure the axial pin is flush with the side of the femoral component | **FIGURE 27.**

NOTE | To help align the components, the Trial Axial Pin can be inserted part way into the opposite side of the final Axial Pin insertion. Then insert the Axial Pin into the other end and advance the pin forward, ejecting the Trial Axial Pin. Engage the Axial Pin until it is flush on both sides of the Distal Femur.

PATELLA RECONSTRUCTION (Optional)

Patella resurfacing is determined based on medical judgment of the clinical situation. If severe degeneration or arthritis is present on the articular surface of the patella, resurfacing may be indicated. If the patella is otherwise normal, such as in a tumor case, and has not been removed for malignant considerations, it may be acceptable to resurface the patella or to leave it in its natural state.

RESURFACING PATELLA

The Resurfacing Patella Resection Guide can be used with or without Resection Depth Gauges or Minimum Thickness Gauges | **FIGURE 28.** When used without gauges, the Resection Guide is positioned at the desired level of resection.



Figure 28.

Securely clamp the jaws into the patella and resect the patellar bone. For a calibrated resection, the appropriate Resection Depth Gauge corresponding to the implant thickness should be attached to the top of the resection guide with the lock screw. Position the resection guide jaws parallel to the articular margin and securely clamp the guide to the bone, assuring the gauge is contacting the apex of the articular surface. The gauge can be removed to increase visibility.

Resurfacing Patella Minimum Thickness Gauges are available for preservation of 10mm or 15mm bone stock. Use of the Minimum Thickness Gauge is based on intraoperative assessment of bone quality and thickness.

Resurfacing Patella, All-Poly, Tri-Peg			
Part Number	Description	Diameter	Thickness
KPONT29E	ELEOS RESURFACING PATELLA	29mm	8mm
KPONT32E	ELEOS RESURFACING PATELLA	32mm	8mm
KPONT35E	ELEOS RESURFACING PATELLA	35mm	8mm
KPONT38E	ELEOS RESURFACING PATELLA	38mm	10mm
KPONT41E	ELEOS RESURFACING PATELLA	41mm	11mm

The Resurfacing Peg Drill Guide is used to size the patella and prepare holes in the bone for the implant pegs. Attach the Resurfacing Peg Drill Guide to the Patella Clamp. The drill guide has grooves on the surface indicating the patella diameter options. The Resurfacing Patella Peg Drill is used to prepare the peg holes | **FIGURE 29**.

NOTE | The Resurfacing Patella have the same peg patterns between sizes and can be easily changed during trial reduction.

NOTE | A Patella/Femoral Head Sizing Caliper is available for assessment of thickness.

Remove the Resurfacing Patella Drill Guide from the Patella Clamp and insert the Patella Clamp Seater in its place.

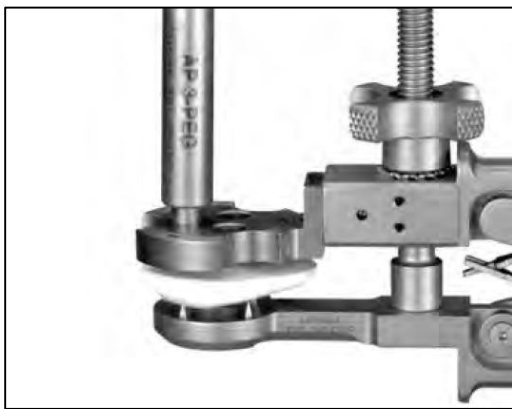

Figure 29.

Once the patella surface is prepared, mix cement, wash and dry the bone, pressurize the cement, and insert pegs into the prepared holes. Use the Patella Clamp with the Patella Clamp Seater attached to fully seat the patella. Remove residual cement and keep the Patella Clamp in place until cement is cured.

COMPONENT DISASSEMBLY

To disengage the ELEOS tapers, insert the Taper Disassembly Tool into the hole on the side of the implant. Strike the end of the tool with a mallet until components separate | **FIGURES 30 AND 31**. Support the implant during disassembly. Alternatively, insert the Taper Disassembly Fork around the outside of the implant, below the seam between the two components to be disassembled. Strike the end of the fork to disengage the tapers | **FIGURES 32 AND 33**. Again, support the implant during disassembly.



Figure 30.



Figure 31.



Figure 32.



Figure 33.

EXPLANTATION INFORMATION

In a revision case, when Segmental Stem explantation is required, use the Stem Extractor Attachment and attach to the Slap Hammer Extractor Handle to remove the stem. To disengage Stem Extensions, use the Stem Implant Extractor-Adaptor. Assemble it to the Slap Hammer Pin Extractor. Next, thread the full assembly to the Stem Extension that needs to be removed. A Trefine from general surgical instrumentation can also be used to remove the stem by placing the Trefine over the stem to ream the bone surrounding the stem.

IMPLANTS

STEM EXTENSIONS (CEMENTED)

PART NUMBER	DESCRIPTION	SIZE
KSC01500E	MODULAR TIBIAL BASE STEM CAP	
KSC01530E	ELEOS STEM EXTENSION	15MM X 30MM
KSC01065E	ELEOS STEM EXTENSION	10MM X 65MM
KSC01265E	ELEOS STEM EXTENSION	12MM X 65MM
KSC01465E	ELEOS STEM EXTENSION	14MM X 65MM
KSC01665E	ELEOS STEM EXTENSION	16MM X 65MM
KSC01865E	ELEOS STEM EXTENSION	18MM X 65MM
KSC10100E	ELEOS STEM EXTENSION	10MM X 100MM
KSC12100E	ELEOS STEM EXTENSION	12MM X 100MM
KSC14100E	ELEOS STEM EXTENSION	14MM X 100MM
KSC16100E	ELEOS STEM EXTENSION	16MM X 100MM
KSC18100E	ELEOS STEM EXTENSION	18MM X 100MM

STEM EXTENSIONS (CANAL FILLING)

PART NUMBER	DESCRIPTION	SIZE
KSP10100E	ELEOS STEM EXTENSION	11MM X 100MM
KSP11100E	ELEOS STEM EXTENSION	12MM X 100MM
KSP12100E	ELEOS STEM EXTENSION	13MM X 100MM
KSP13100E	ELEOS STEM EXTENSION	14MM X 100MM
KSP14100E	ELEOS STEM EXTENSION	15MM X 100MM
KSP15100E	ELEOS STEM EXTENSION	16MM X 100MM
KSP16100E	ELEOS STEM EXTENSION	17MM X 100MM
KSP17100E	ELEOS STEM EXTENSION	18MM X 100MM
KSP18100E	ELEOS STEM EXTENSION	19MM X 100MM
KSP20100E	ELEOS STEM EXTENSION	21MM X 100MM
KSP22100E	ELEOS STEM EXTENSION	23MM X 100MM
KSP10140E	ELEOS STEM EXTENSION	11MM X 140MM
KSP11140E	ELEOS STEM EXTENSION	12MM X 140MM
KSP12140E	ELEOS STEM EXTENSION	13MM X 140MM
KSP13140E	ELEOS STEM EXTENSION	14MM X 140MM
KSP14140E	ELEOS STEM EXTENSION	15MM X 140MM
KSP15140E	ELEOS STEM EXTENSION	16MM X 140MM
KSP16140E	ELEOS STEM EXTENSION	17MM X 140MM
KSP17140E	ELEOS STEM EXTENSION	18MM X 140MM

ELEOS Limb Salvage System

KSP18140E	ELEOS STEM EXTENSION	19MM X 140MM
KSP20140E	ELEOS STEM EXTENSION	21MM X 140MM

RESURFACING FEMURS

PART NUMBER	DESCRIPTION	SIZE
2500L002E	RESURFACING FEMUR SIZE 2 LEFT	60MM M/L
2500L003E	RESURFACING FEMUR SIZE 3 LEFT	65MM M/L
2500L004E	RESURFACING FEMUR SIZE 4 LEFT	70MM M/L
2500R002E	RESURFACING FEMUR SIZE 2 RIGHT	60MM M/L
2500R003E	RESURFACING FEMUR SIZE 3 RIGHT	65MM M/L
2500R004E	RESURFACING FEMUR SIZE 4 RIGHT	65MM M/L

RESURFACING FEMUR AXIAL PINS

PART NUMBER	DESCRIPTION	SIZE
25002112E	ELEOS RESURFACING FEMUR AXIAL PIN	SIZE 2
25002113E	ELEOS RESURFACING FEMUR AXIAL PIN	SIZE 3
25002114E	ELEOS RESURFACING FEMUR AXIAL PIN	SIZE 4

TIBIAL HINGE COMPONENTS

PART NUMBER	DESCRIPTION	SIZE
25002100E	ELEOS TIBIAL HINGE COMPONENT W/ ROTATIONAL STOP	
25002101E	ELEOS TIBIAL HINGE COMPONENT W/O ROTATIONAL STOP	

TIBIAL POLY SPACERS

PART NUMBER	DESCRIPTION	SIZE
25001208E	ELEOS TIBIAL POLY SPACER	8MM
25001210E	ELEOS TIBIAL POLY SPACER	10MM
25001212E	ELEOS TIBIAL POLY SPACER	12MM
25001216E	ELEOS TIBIAL POLY SPACER	16MM
25001220E	ELEOS TIBIAL POLY SPACER	20MM

PROXIMAL TIBIA

PART NUMBER	DESCRIPTION	SIZE
25002200E	ELEOS PROXIMAL TIBIA	87MM RESECTION

MALE-FEMALE MIDSECTIONS

PART NUMBER	DESCRIPTION	SIZE
25001040E	ELEOS MALE-FEMALE MIDSECTION	40MM
25001050E	ELEOS MALE-FEMALE MIDSECTION	50MM
25001060E	ELEOS MALE-FEMALE MIDSECTION	60MM
25001070E	ELEOS MALE-FEMALE MIDSECTION	70MM
25001090E	ELEOS MALE-FEMALE MIDSECTION	90MM
25001110E	ELEOS MALE-FEMALE MIDSECTION	110MM
25001140E	ELEOS MALE-FEMALE MIDSECTION	140MM

SEGMENTAL STEMS (CEMENTED)

PART NUMBER	DESCRIPTION	SIZE
25004009E	ELEOS SEGMENTAL STEM	9MM X 120MM
25004011E	ELEOS SEGMENTAL STEM	11MM X 120MM
25004013E	ELEOS SEGMENTAL STEM	13MM X 120MM
25000011E	ELEOS SEGMENTAL STEM	11MM X 152MM
25000013E	ELEOS SEGMENTAL STEM	13MM X 152MM
2500CC15E	ELEOS SEGMENTAL STEM	15MM X 152MM
2500CC17E	ELEOS SEGMENTAL STEM	17MM X 152MM
SPSEB011E	ELEOS SEGMENTAL STEM	11MM X 152MM
SPSEB013E	ELEOS SEGMENTAL STEM	13MM X 152MM
SPSEB015E	ELEOS SEGMENTAL STEM	15MM X 152MM
SPSEB017E	ELEOS SEGMENTAL STEM	17MM X 152MM

SEGMENTAL STEMS (CANAL FILLING)

PART NUMBER	DESCRIPTION	SIZE
2500SP12E	ELEOS SEGMENTAL STEM	12MM X 120MM
2500SP14E	ELEOS SEGMENTAL STEM	14MM X 120MM
2500SP16E	ELEOS SEGMENTAL STEM	16MM X 120MM
2500SP18E	ELEOS SEGMENTAL STEM	18MM X 120MM
2500SP20E	ELEOS SEGMENTAL STEM	20MM X 120MM
2500SP22E	ELEOS SEGMENTAL STEM	22MM X 120MM
2500BP12E	ELEOS SEGMENTAL STEM	12MM X 152MM
2500BP14E	ELEOS SEGMENTAL STEM	14MM X 152MM
2500BP16E	ELEOS SEGMENTAL STEM	16MM X 152MM
2500BP18E	ELEOS SEGMENTAL STEM	18MM X 152MM
2500BP20E	ELEOS SEGMENTAL STEM	20MM X 152MM
2500BP22E	ELEOS SEGMENTAL STEM	22MM X 152MM
2500CP12E	ELEOS SEGMENTAL STEM	12MM X 152MM
2500CP14E	ELEOS SEGMENTAL STEM	14MM X 152MM
2500CP16E	ELEOS SEGMENTAL STEM	16MM X 152MM
SPSE0002E	ELEOS SEGMENTAL STEM	12MM X 152MM
SPSE0003E	ELEOS SEGMENTAL STEM	14MM X 152MM
SPSE0004E	ELEOS SEGMENTAL STEM	16MM X 152MM
SPSE0005E	ELEOS SEGMENTAL STEM	18MM X 152MM

RESURFACING PATELLAS

PART NUMBER	DESCRIPTION	SIZE
KPONTP29E	ELEOS RESURFACING PATELLA, ALL-POLY, TRI-PEG	29MM
KPONTP32E	ELEOS RESURFACING PATELLA, ALL-POLY, TRI-PEG	32MM
KPONTP35E	ELEOS RESURFACING PATELLA, ALL-POLY, TRI-PEG	35MM
KPONTP38E	ELEOS RESURFACING PATELLA, ALL-POLY, TRI-PEG	38MM
KPONTP41E	ELEOS RESURFACING PATELLA, ALL-POLY, TRI-PEG	41MM

INSTRUMENTS

REAMERS

PART NUMBER	DESCRIPTION	SIZE
K0051010E	CYLINDRICAL REAMER	10MM
K0050510E	CYLINDRICAL REAMER	10.5MM
K0051011E	CYLINDRICAL REAMER	11MM
K0050511E	CYLINDRICAL REAMER	11.5MM
K0051012E	CYLINDRICAL REAMER	12MM
K0050512E	CYLINDRICAL REAMER	12.5MM
K0051013E	CYLINDRICAL REAMER	13MM
K0050513E	CYLINDRICAL REAMER	13.5MM
K0051014E	CYLINDRICAL REAMER	14MM
K0050514E	CYLINDRICAL REAMER	14.5MM
K0051015E	CYLINDRICAL REAMER	15MM
K0050515E	CYLINDRICAL REAMER	15.5MM
K0051016E	CYLINDRICAL REAMER	16MM
K0050516E	CYLINDRICAL REAMER	16.5MM
K0051017E	CYLINDRICAL REAMER	17MM
K0050517E	CYLINDRICAL REAMER	17.5MM
K0051018E	CYLINDRICAL REAMER	18MM
K0050518E	CYLINDRICAL REAMER	18.5MM
K0051019E	CYLINDRICAL REAMER	19MM
K0050519E	CYLINDRICAL REAMER	19.5MM
K0051020E	CYLINDRICAL REAMER	20MM
K0050520E	CYLINDRICAL REAMER	20.5MM
K0051021E	CYLINDRICAL REAMER	21MM
K0050521E	CYLINDRICAL REAMER	21.5MM
K0051022E	CYLINDRICAL REAMER	22MM
K0050522E	CYLINDRICAL REAMER	22.5MM
K0051023E	CYLINDRICAL REAMER	23MM
K0051116E	STABILIZING COLLET	16MM
K0051118E	STABILIZING COLLET	18MM
K0051120E	STABILIZING COLLET	20MM
K0051122E	STABILIZING COLLET	22MM
K0051124E	STABILIZING COLLET	24MM
001-03-00001	REAMERS (TRAY 1)	
001-03-00016	TRAY LID STANDARD	

ASSEMBLY/DISASSEMBLY INSTRUMENTS

PART NUMBER	DESCRIPTION	SIZE
18041000E	SLAP HAMMER EXTRACTOR HANDLE	
25100008E	TIBIAL BASEPLATE ASSEMBLY PLATFORM	
25107000E	TAPER DISASSEMBLY TOOL	
25107001E	TAPER DISASSEMBLY FORK	
25107101E	FEMORAL ASSEMBLY PLATFORM	
25107500E	MIDSECTION ASSEMBLY IMPACTOR	
25107501E	STEM ASSEMBLY IMPACTOR	
25107600E	FEMORAL IMPACTOR	
25107601E	DISTAL FEMORAL EXTRACTOR	
25107602E	TIBIAL IMPACTOR	
001-03-00002	ASSEMBLY/DISASSEMBLY INSTRUMENTS (TRAY 2)	
001-03-00016	TRAY LID STANDARD	

SEGMENTAL STEM TRIALS

PART NUMBER	DESCRIPTION	SIZE
25100011E	TRIAL SEGMENTAL STEM	11MM X 152MM
25100013E	TRIAL SEGMENTAL STEM	13MM X 152MM
25100015E	TRIAL SEGMENTAL STEM	15MM X 152MM
25100017E	TRIAL SEGMENTAL STEM	17MM X 152MM
SPSETB11E	TRIAL SEGMENTAL STEM	11MM X 152MM
SPSETB13E	TRIAL SEGMENTAL STEM	13MM X 152MM
SPSETB15E	TRIAL SEGMENTAL STEM	15MM X 152MM
SPSETB17E	TRIAL SEGMENTAL STEM	17MM X 152MM
25104009E	TRIAL SEGMENTAL STEM	9MM X 120MM
25104011E	TRIAL SEGMENTAL STEM	11MM X 120MM
25104013E	TRIAL SEGMENTAL STEM	13MM X 120MM
25107400E	STEM EXTRACTOR ATTACHMENT	
25107201E	UNIVERSAL RESECTION PLANER	
25107207E	RESECTION PLANER	7MM
25107209E	RESECTION PLANER	9MM
25107211E	RESECTION PLANER	11MM
20040110E	PILOT POINT #10	
20040111E	PILOT POINT #11	
20040112E	PILOT POINT #12	
20040113E	PILOT POINT #13	
20040114E	PILOT POINT #14	
20040115E	PILOT POINT #15	
001-03-00003	SEGMENTAL STEM TRIALS (TRAY 3)	
001-03-00016	TRAY LID STANDARD	

STEM EXTENSION TRIALS

PART NUMBER	DESCRIPTION	SIZE
K0050010E	TRIAL STEM EXTENSION	10MM X 100MM
K0050011E	TRIAL STEM EXTENSION	11MM X 100MM
K0050012E	TRIAL STEM EXTENSION	12MM X 100MM
K0050013E	TRIAL STEM EXTENSION	13MM X 100MM
K0050014E	TRIAL STEM EXTENSION	14MM X 100MM
K0050015E	TRIAL STEM EXTENSION	15MM X 100MM
K0050016E	TRIAL STEM EXTENSION	16MM X 100MM
K0050017E	TRIAL STEM EXTENSION	17MM X 100MM
K0050018E	TRIAL STEM EXTENSION	18MM X 100MM
K0050020E	TRIAL STEM EXTENSION	20MM X 100MM
K0050022E	TRIAL STEM EXTENSION	22MM X 100MM
K0051005E	STEM IMPLANT EXTRACTOR-ADAPTOR	
K0051410E	TRIAL STEM EXTENSION	10MM X 140MM
K0051411E	TRIAL STEM EXTENSION	11MM X 140MM
K0051412E	TRIAL STEM EXTENSION	12MM X 140MM
K0051413E	TRIAL STEM EXTENSION	13MM X 140MM
K0051414E	TRIAL STEM EXTENSION	14MM X 140MM
K0051415E	TRIAL STEM EXTENSION	15MM X 140MM
K0051416E	TRIAL STEM EXTENSION	16MM X 140MM
K0051417E	TRIAL STEM EXTENSION	17MM X 140MM
K0051418E	TRIAL STEM EXTENSION	18MM X 140MM
K0051420E	TRIAL STEM EXTENSION	20MM X 140MM
K0051530E	TRIAL STEM EXTENSION	15MM X 30MM
K0056510E	TRIAL STEM EXTENSION	10MM X 65MM
K0056512E	TRIAL STEM EXTENSION	12MM X 65MM
K0056514E	TRIAL STEM EXTENSION	14MM X 65MM
K0056516E	TRIAL STEM EXTENSION	16MM X 65MM
K0056518E	TRIAL STEM EXTENSION	18MM X 65MM
001-03-00005	STEM EXTENSION TRIALS (TRAY 5)	
001-03-00016	TRAY LID STANDARD	

GENERAL RESURFACING INSTRUMENTS

PART NUMBER	DESCRIPTION	SIZE
18055001E	UNIVERSAL HUDSON ADAPTOR	
25102211E	AXIAL PIN INSERTER/ EXTRACTOR	
25107613E	TIBIAL BASEPLATE PRESS FIT REAMER	
25107614E	TIBIAL BASEPLATE CEMENTED REAMER	
K0000900E	EXTERNAL CHECK GUIDE	
K0000901E	EXTERNAL CHECK ROD	
K0001002E	STARTER DRILL BIT 3/8 IN	
K0001005E	DRILL BIT 1/8 IN	
K0001006E	QUICK DISCONNECT FOR 1/8" DRILL BIT	
K0001015E	DRILL BIT 1/8IN X 100MM	
K0001016E	QUICK DISCONNECT T-HANDLE	
K0001101E	11 IN REAMER/IM ROD	
K0002007E	TIBIAL BASEPLATE FIXATION PIN	
K0002008E	SLAP HAMMER PIN EXTRACTOR	
K0002010E	PIN PULLER	
K0002011E	FIXATION PIN, HEADLESS	80MM
K0002015E	PIN INSERTER	
K0014407E	DUAL REFERENCE GAUGE	
001-03-00014	PIN CADDY	
001-03-00008	GENERAL RESURFACING INSTRUMENTS (TRAY 8)	
001-03-00016	TRAY LID STANDARD	

FEMORAL RESURFACING INSTRUMENTS

PART NUMBER	DESCRIPTION	SIZE
2510L002E	TRIAL RESURFACING FEMUR	SIZE 2
2510L003E	TRIAL RESURFACING FEMUR	SIZE 3
2510L004E	TRIAL RESURFACING FEMUR	SIZE 4
2510R002E	TRIAL RESURFACING FEMUR	SIZE 2
2510R003E	TRIAL RESURFACING FEMUR	SIZE 3
2510R004E	TRIAL RESURFACING FEMUR	SIZE 4
25107809E	FEMORAL DISTAL SPACER	9MM
25102113E	TRIAL AXIAL PIN	
K0056010E	IM REVISION ANGLE LOCATOR	5 DEGREE
K0011001E	VALGUS ANGLE ALIGNMENT GUIDE	
25107808E	DISTAL FEMORAL RESECTION GUIDE	
25107802E	FEMORAL A/P RESECTION GUIDE	SIZE 2
25107803E	FEMORAL A/P RESECTION GUIDE	SIZE 3
25107804E	FEMORAL A/P RESECTION GUIDE	SIZE 4
001-03-00009	FEMORAL RESURFACING INSTRUMENTS (TRAY 9)	
001-03-00016	TRAY LID STANDARD	

PATELLA INSTRUMENTS

PART NUMBER	DESCRIPTION	SIZE
18410213E	PATELLA/FEMORAL HEAD SIZING CALIPER	
18810210E	RESURFACING PATELLA RESECTION GAUGE	10MM
18810220E	RESURFACING PATELLA RESECTION GUIDE	
18810228E	RESURFACING PATELLA DEPTH GAUGE	8MM
18811210E	RESURFACING PATELLA MINIMUM THICKNESS GAUGE	10MM
18811215E	RESURFACING PATELLA MINIMUM THICKNESS GAUGE	15MM
18812211E	RESURFACING PATELLA THICKNESS RESECTION GAUGE	11MM
K0031000E	PATELLA CLAMP	
K0031001E	PATELLA CLAMP SEATER	
K0031002E	RESURFACING PATELLA PEG DRILL GUIDE	
K0031013E	RESURFACING PATELLA PEG DRILL	
KPTRTP32E	TRIAL RESURFACING PATELLA	32MM
KPTRTP35E	TRIAL RESURFACING PATELLA	35MM
KPTRTP38E	TRIAL RESURFACING PATELLA	38MM
KPTRTP41E	TRIAL RESURFACING PATELLA	41MM
001-03-00010	PATELLA INSTRUMENTS (TRAY 10)	
001-03-00016	TRAY LID STANDARD	

PROXIMAL TIBIA TRIALS

PART NUMBER	DESCRIPTION	SIZE
25101208E	TRIAL TIBIAL POLY SPACER	8MM
25101210E	TRIAL TIBIAL POLY SPACER	10MM
25101212E	TRIAL TIBIAL POLY SPACER	12MM
25101216E	TRIAL TIBIAL POLY SPACER	16MM
25101220E	TRIAL TIBIAL POLY SPACER	20MM
25102100E	TRIAL TIBIAL HINGE COMPONENT	
25102200E	TRIAL PROXIMAL TIBIA	
25100040E	TRIAL MALE-FEMALE MIDSECTION	40MM
25100050E	TRIAL MALE-FEMALE MIDSECTION	50MM
25100060E	TRIAL MALE-FEMALE MIDSECTION	60MM
001-03-00011	PROXIMAL TIBIA TRIALS (TRAY 11)	
001-03-00015	TRAY LID SMALL	

X-RAY TEMPLATES

PART NUMBER	DESCRIPTION	SIZE
G015XRGSE	X-RAY TEMPLATES	

ELEOS Limb Salvage System

The ELEOS Limb Salvage System is compatible with the following MicroPort Orthopedics systems trademarked by MicroPort: Guardian, Advance, Gladiator, Lineage, and Transcend.

ELEOS is a trademark of Onkos Surgical.

©2017, Onkos Surgical. All Rights Reserved.

ELSS PT.12.13.16 v0

Onkos Surgical

77 East Halsey Road

Parsippany, NJ 07054

973.264.5400 phone

www.onkossurgical.com/ELEOS